

WINCH TENSION

ROLLER TENSION

> Model CS154, CS154-R, CS154-L

- Suitabel to control winches Tension

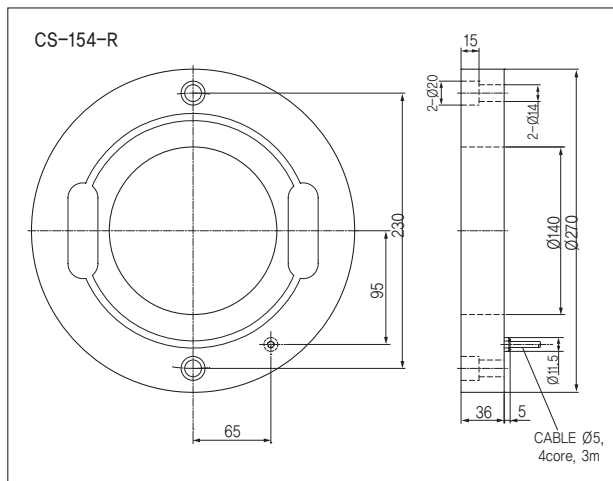
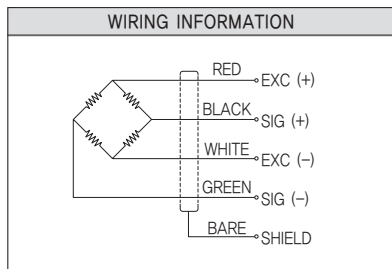

> DIMENSIONS TABLE

Specifications	Accuracy
RATED CAPACITY (R.C.)	2.5tf
RATED OUTPUT (R.O.)	1mV/V±1%
NON-LINEARITY	0.15% R.O.
HYSTERESIS	0.15% R.O.
REPEATABILITY	0.1% R.O.
ZERO BALANCE	±2% R.O.
TEMP. RANGE COMPENSATED	-10°C ~ 60°C
SAFE TEMPERATURE RANGE	-20°C ~ 70°C
TEMP. EFFECT ON RATED OUTPUT	±0.1%LOAD/10°C
TEMP. EFFECT ON ZERO BALANCE	±0.1%R.O./10°C
RESISTANCE, INPUT	700 Ohm±10
RESISTANCE, OUTPUT	700 Ohm±5
INSULATION RESISTANCE BRIDGE TO GROUND	2000MΩ
ELECTRICAL CONNECTION	Ø5mm x 4C x 3m
EXC. RECOMMENDED	10V
SAFE OVERLOAD	120% R.C.
Surface Finish	Zinc galvanizing

> Model RTB9

- Suitabel to control Roller Tension

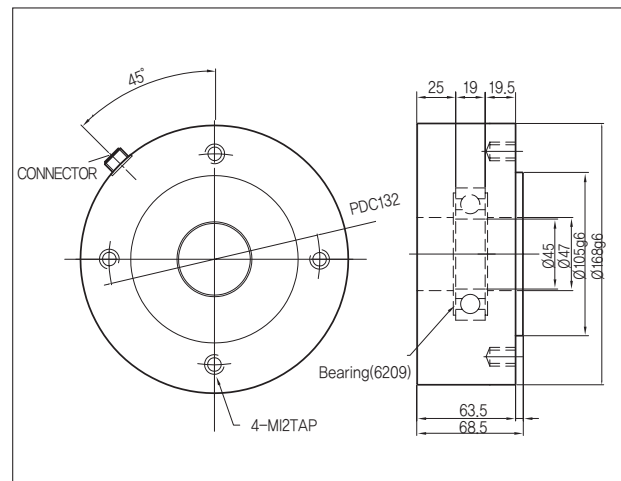
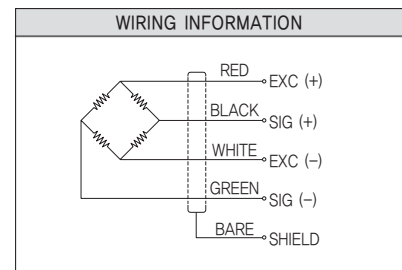

> DIMENSIONS TABLE

Specifications	Accuracy
RATED CAPACITY (R.C.)	3tf
RATED OUTPUT (R.O.)	1mV/V ±1%
NON-LINEARITY	0.1% R.O.
HYSTERESIS	0.1% R.O.
REPEATABILITY	0.05% R.O.
EXC. RECOMMENDED	10V
SAFE TEMPERATURE RANGE	-20°C ~ 70°C
TEMP. RANGE COMPENSATED	-10°C ~ 60°C
TEMP. EFFECT ON RATED OUTPUT	±0.1%LOAD/10°C
TEMP. EFFECT ON ZERO BALANCE	±0.1%R.O./10°C
TERMINAL RESISTANCE	350 Ohm±1%
INSULATION RESISTANCE BRIDGE TO GROUND	2000MΩ
ELECTRICAL CONNECTION	Ø5mm x 4C x 3m
SAFE OVERLOAD	200% R.C.

★Specifications are subject to change without notice.