

# Low Profile Compression Load Cell

## >Model UL277

Pancake type load cell.  
 Alloy steel construction.  
 High accuracy, Low profile, Easy to install.  
 Protected against corrosion by nickel plated treatment  
 Suitable for testing machine and hopper scales, etc.

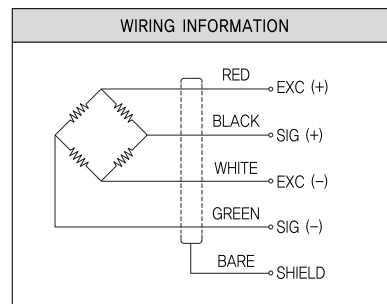
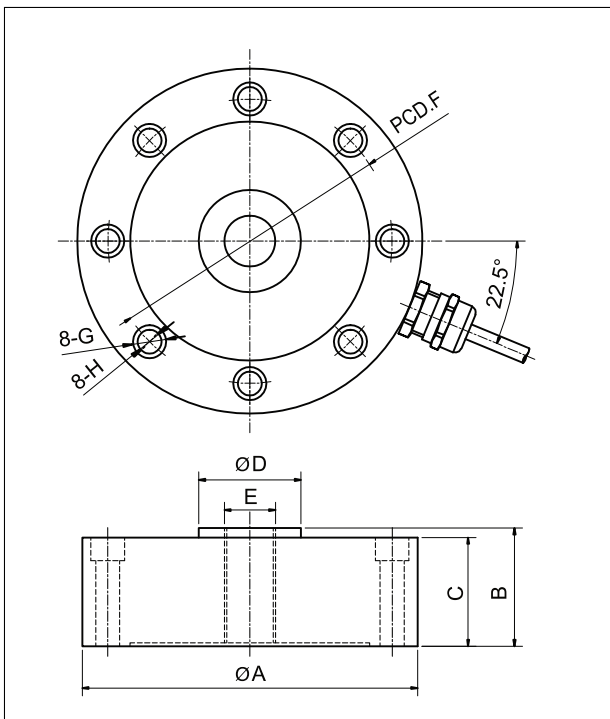
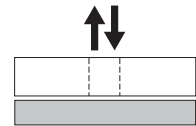

## >SPECIFICATIONS

Specifications	Accuracy
Rated capacity(R.C.)	1t, 2t, 3t, 5t, 10t, 15t, 20t, 25t, 30t
Rated output(R.O.)	2mV/V ±0.5%
Nonlinearity	0.05% of R.O.
Hysteresis	0.05% of R.O.
Reperatability	0.05% of R.O.
Zero balance	±1% of R.O.
Temp. effect on rated output	±0.05% of LOAD/10°C
Temperature effect on zero balance	±0.05% of R.O./10°C
Temperature range, compensated	-10~60°C
Temperature range, safe	-20~80°C
Terminal resistance, input	700±10Ω
Terminal resistance, output	700±5Ω
Insulation resistance bridge	2000MΩ
Excitation recommended	10V
Safe overload	150% R.C.
Cable length	Ø5mm 4core, 3m

## >DIMENSIONS TABLE

unit:mm

Model	ØA	B	C	ØD	E	F	G	H
1t, 2t, 3t, 5t	105	37	34	32	M16×1.5	89	Ø10.5 DP 7.2	Ø7.5
10t, 15t, 20t, 25t	120.6	53.5	41	39	M32×1.5	101.8	Ø14 DP 10.5	Ø8.5
30t	141	57.2	50.8	50.4	M40×1.5	116.8	Ø18 DP 11	Ø11

★Specifications are subject to change without notice.