

# Weighing Module

## >Weighing Modue CMI-96

Compact design.  
 Material Zinc plated steel.  
 Integrated horizontal stops.  
 Using loadcell : CM96

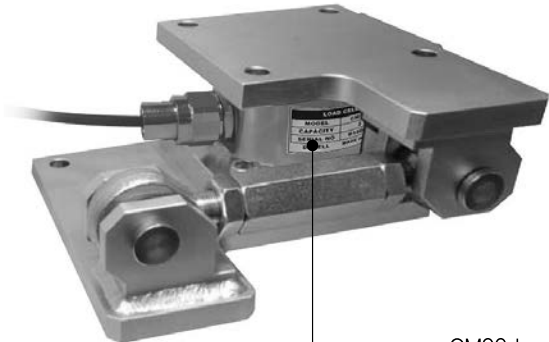

CM96 Load cell

### >DIMENSIONS

unit:mm

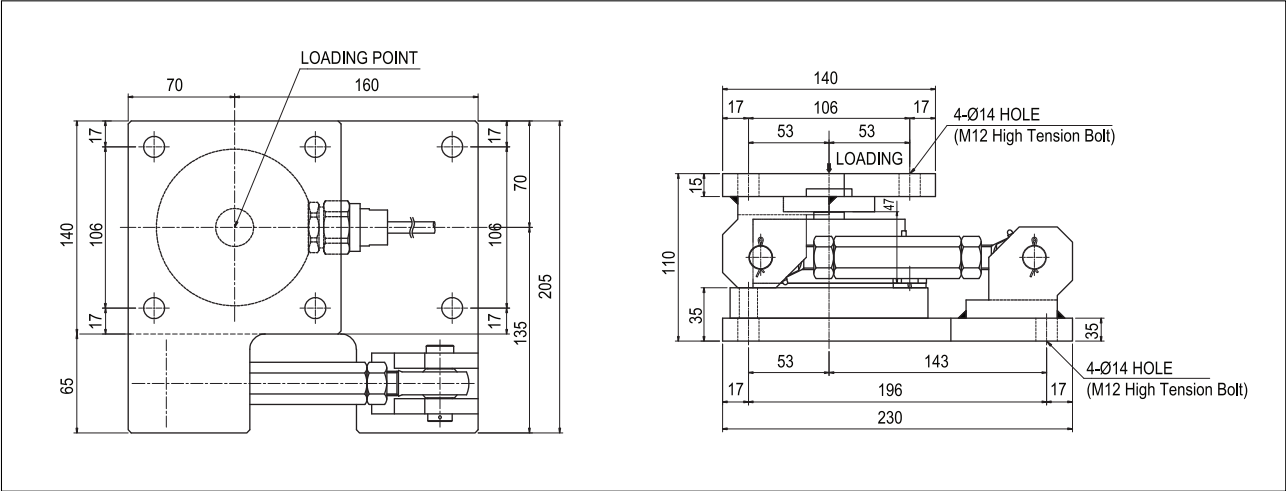

### Stay rod Installation Direction

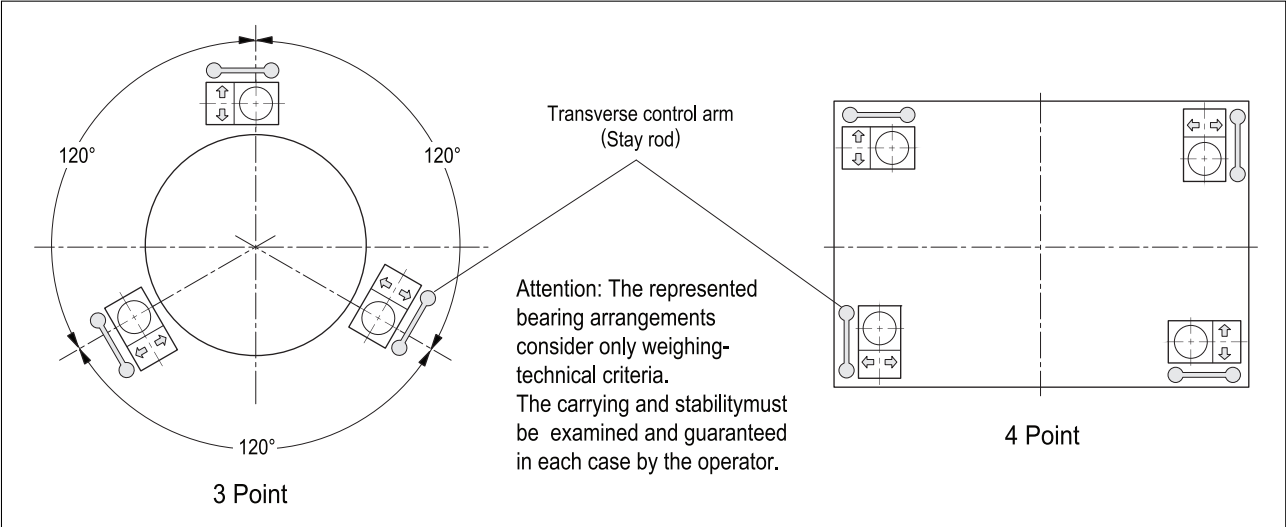

★Specifications are subject to change without notice.