

# Miniature Compression Load Cells

## >Model CMM92, CMM97

Small-Sized Compression Load Cell.  
Super compact and lightweight.  
Competitive price.

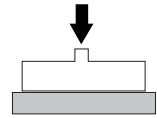

CMM92



CMM97

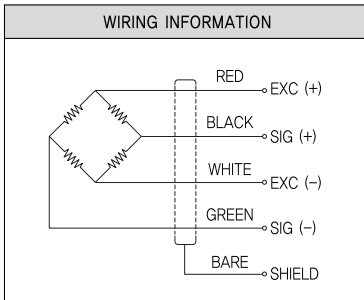

CMM92

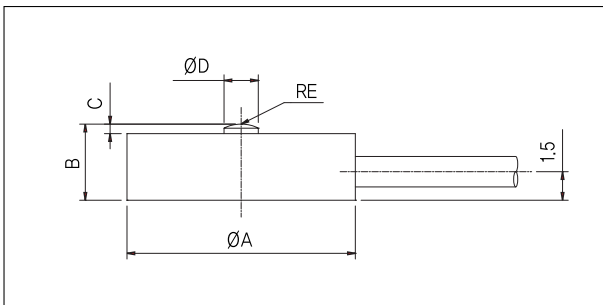

CMM97

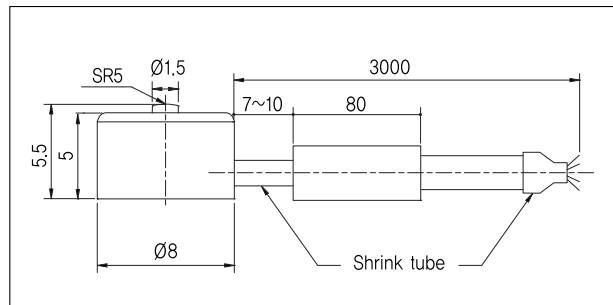

## >SPECIFICATIONS

Specifications	Accuracy	
	CMM92	CMM97
Rated capacity(R.C.)	1kgf, 2kgf, 5kgf, 10kgf, 20kgf	20kgf ~ 50kgf
Rated output(R.O.)	0.5 or more(mV/V)	
Nonlinearity	±1% of R.O.	
Hysteresis	±1% of R.O.	
Repeatability	1% of R.O.	
Zero balance	±2% of R.O.	
Temperature range, compensated	0~40°C	
Temperature range, safe	-10~60°C	
Temperature effect on rated output	±2%LOAD/10°C	
Temperature effect on zero balance	±2%R.O./10°C	
Terminal resistance	350Ω ±2.5%	
Insulation resistance bridge/case	2000MΩ	
Electrical connenction	Ø1.6 × 4C × 3m	
Excitation recommended	5V	
Safe overload	120% R.C.	
Material	Aluminum(1kgf, 2kgf)/Stainless steel(5kgf, 10kgf, 20kgf)	Stainless steel

## >DIMENSIONS TABLE (CMM92)

unit:mm

Capacity	ØA	B	C	ØD	E
1kgf ~ 5kgf	12	4	0.5	1.8	2
10kgf ~ 20kgf	15	4	0.5	2.5	4

★Specifications are subject to change without notice.