

Compression Load Cell

>Model UL12

Canister, through-hole type.
Suitable for application in injection molding machines.

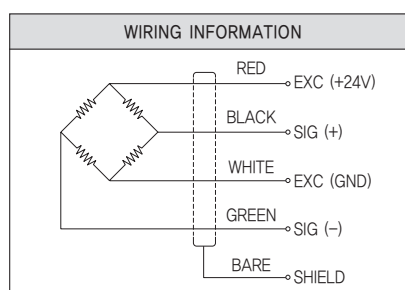
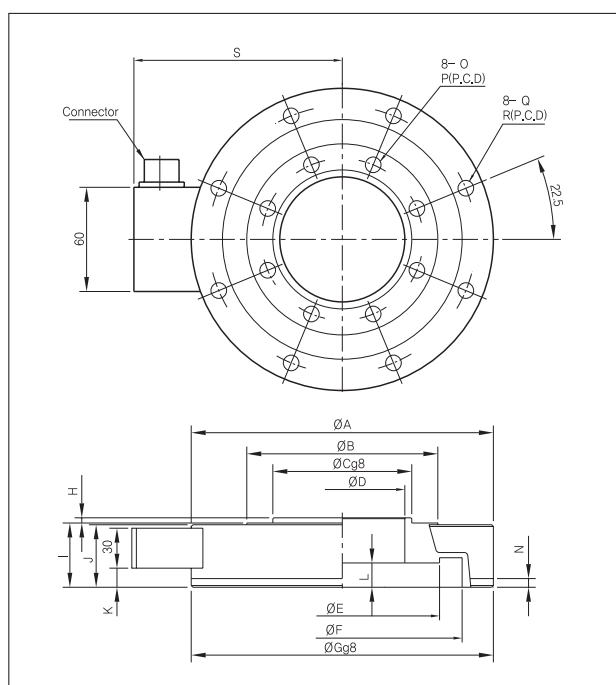

>SPECIFICATIONS

Specifications	Accuracy
Rated capacity	6tf~50tf (58.84kN~490.3kN)
Safe overload	150% R.C.
Nonlinearity	0.6% R.O.
Hysteresis	0.6% R.O.
Repeatability	0.2% R.O.
Current output	4mA to 20mA (3 wires method, Load resistance 500 or less, at 24)
Power supply voltage	DC 24V
Temperature range, compensated	0°C to 60°C
Temperature range, safe	-10°C to 70°C
Temperature effect on zero balance	0.15% R.O./10°C
Temperature effect on output	0.15% LOAD/10°C
Cable	4 cores shielded 5m
Class of protection	Equivalent to IP64. (main body only)
Materials of the element	Alloy steel
Durability	10 ⁶ times with rated capacity.

>DIMENSIONS TABLE

unit:mm

Model	Capacity	A	B	C	D	E	F	G	H	I	J	K	L	N	O	P	Q	R	S	Weight (Approx. kg)
UL12-T6	58.84kN	174	110	80	72	112	138	181	3	37	37	6	14	5	9	93	9	154	120	8
UL12-T8	78.45kN																			
UL12-T12	118kN	180	110	80	70	112	138	181	5	60	59.5	26	17	10	9	93	9	160	123	10
UL12-T15	147.1kN																			
UL12-T20	196.1kN																			
UL12-T27	265kN	275	180	135	110	182	208	276	5	60	60	26	17	10	13	160	13	247	171	19
UL12-T34	333.4kN																			
UL12-T50	490.3kN																			

★Specifications are subject to change without notice.