

| NO | DATE | ZONE | REVISION | CO'T | SIGN |
|----|------|------|----------|------|------|
| △  |      |      |          |      |      |

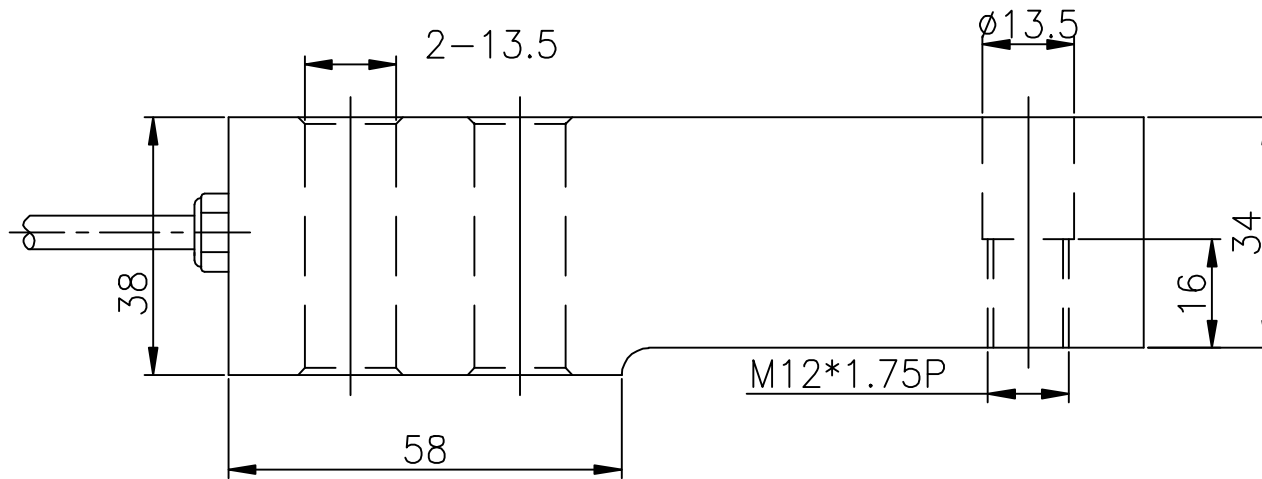
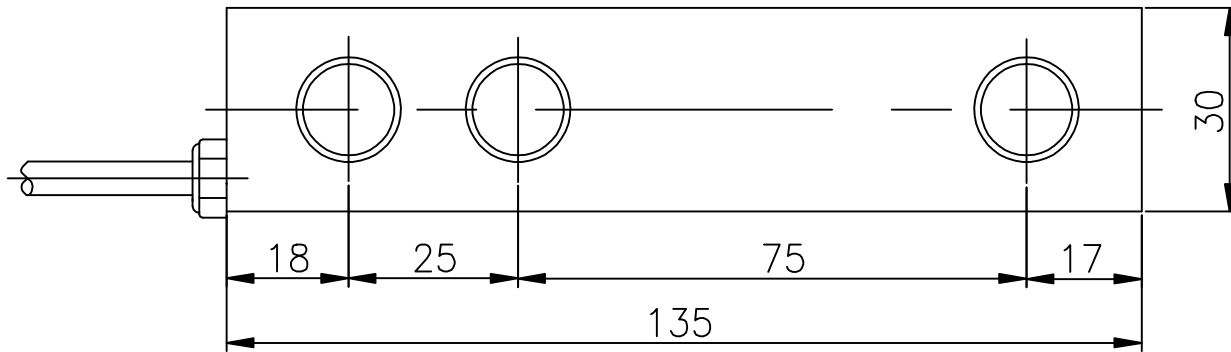

### SPECIFICATION

|   |                 |
|---|-----------------|
| MODEL                                     | CPC3            |
| RATED CAPACITY (R.C.)                     | 3tf             |
| RATED OUTPUT (R.O.)                       | 2.0mV/V ± 0.1%  |
| NON-LINEARITY                             | 0.03% R.O.      |
| HYSTERESIS                                | 0.02% R.O.      |
| REPEATABILITY                             | 0.02% R.O.      |
| ZERO BALANCE                              | ±5% R.O.        |
| TEMP. RANGE COMPENSATED                   | -10°C~50°C      |
| SAFE TEMPERATURE RANGE                    | -20°C~80°C      |
| TEMP. EFFECT ON RATED OUTPUT              | ±0.02%LOAD/10°C |
| TEMP. EFFECT ON ZERO BALANCE              | ±0.05%R.O./10°C |
| RESISTANCE, INPUT                         | 350 Ohm ± 30    |
| RESISTANCE, OUTPUT                        | 350 Ohm ± 3     |
| INSULATION RESISTANCE<br>BRIDGE TO GROUND | 2000MΩ          |
| ELECTRICAL CONNECTION                     | ∅5mm x 4C x 3m  |
| EXC. RECOMMENDED                          | 10V             |
| SAFE OVERLOAD                             | 150% R.C.       |

| NO  | DESCRIPTION                    | MATERIAL     | HEAT TREAT       | Q'TY                  | DIMENSIONS                | REMARK                    |
|---|--------------------------------|--------------|------------------|-----------------------|---------------------------|---------------------------|
| CHAMFER                                   |                                | SCALE 1 : 1  | ANGLE 1st 3rd    | DESCRIPTION LOAD CELL |                           |                           |
| <input type="checkbox"/> C 0.1            | <input type="checkbox"/> C 0.3 | DRAWN BY JJS | PLANNED BY       | CHECKED BY            | APPROVED BY               | ORDER. CPC3-T3            |
| <input checked="" type="checkbox"/> C 0.5 | <input type="checkbox"/> C 1   | 2020.03.30   | TEL 043-260-2242 |                       | ORDER DWG. NO. CPC3-1A-T3 |                           |
| TOLERANCE LIMITS                          |                                | DACELL       |                  | FAX 043-260-2245      |                           | MAKER DWG. NO. CPC3-1A-T3 |
| <input checked="" type="checkbox"/> MM    | <input type="checkbox"/> INCH  | SHEET        |                  |                       |                           |                           |
| 0. ±0.1                                   | 0.0 ±0.04                      |              |                  |                       |                           |                           |
| 0.0 ±0.05                                 | 0.00 ±0.02                     |              |                  |                       |                           |                           |
| 0.00 ±0.01                                | 0.000 ±0.004                   |              |                  |                       |                           |                           |
| 0.000 ±0.002                              | 0.0000 ±0.0002                 |              |                  |                       |                           |                           |