

MODEL : DN-20W
DIGITAL INDICATOR

USER'S MANUAL

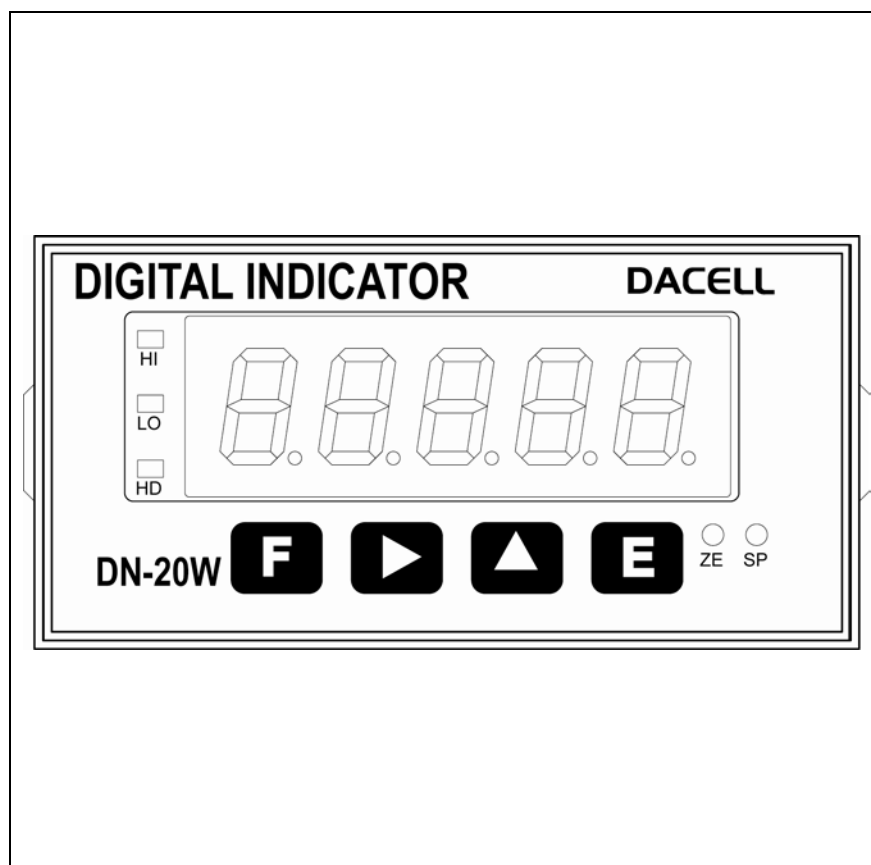

DACELL CO.,LTD.

Address : 681-1 Cheoksan-Ri, Nami-Myeon, Cheongweon-Gun,
Chung-buk

TEL :82-43-260-2242

FAX : 82-43-260-2245

<http://www.dacell.com>

E-Mail : info@dacell.com

Contents

1. Features	2
1-1. High-speed conversion method	2
1-2. Calibration method	2
1-3. HOLD & PEAK HOLD	2
1-4. Comparison Output	2
1-5. Data Back-up	2
1-6. Watch dog	3
1-7. Option	3
1-8. Power	3
2. Attention	4
2-1. Attention for installation	4
2-2. Attention for use	4
3. Specification	5
4. Front Panel	6
5. Rear Panel	7
6. Wiring Diagram	9
7. Components & Function	10
7-1. Flow Chart	10
7-2. How to use Hold mode	11
7-3. How to use comparison output function	12
8. Setting mode	14
8-1. Types of Setting mode & Set-up	14
8-2. Function mode (Function Set-up)	15
8-3. Digital calibration (Calibration by sensor output value)	21
8-4. Real-weight Calibration	22
8-5. Lock Set-up	23
9. OPTION (OP-02, OP-03)	
Option 02 (RS232C)	24
Option 03 (RS485)	26

1. Feature

We are grateful to you for picking up our product. If you experience problems while using it, you may refer to the user manual or contact the Technical Support Department of the company.

This product is an indicator which amplifies the minute voltage signals of each sensor and converts them into digital. It is mainly used in Physics quantity measurement for voltage output and current output, pressure sensor, and LVDT, etc. It has the following features.

1-1. Medium & High-speed Conversion Method

16bit High-speed A/D converter that can detect the sensor's input signal at a rate of 100 times per second is used.

For analog output, 12bit D/A converter with 100 times per second is used so that there is almost no deviation between display value and output value.

1-2. Calibration Method

2 types of calibration systems are adopted. Calibration by actual load (standard weight) and calibration by rated output of sensor (mV/V).

1-3. Hold & Peak Hold

You can choose Analog peak hold (High-speed) or Digital peak hold (Low-speed) as per your need.

1-4. Comparison Output

You can do set-up the maximum and lower limit value by the keys on the front panel and print with contact point signal of the rear panel.

1-5. Data Back-up

All the set-up values will be memorized on the flash memory so the inputted data can be saved and no need to do the re-setting even in case of the interruption of the electric power or power disconnection.

1-6. Watch dog

This function is for automatic reset in case the system is stopped due to the external factors such as noise.

1-7. Option

You can use RS232C, RS485 as the optional specification.

1-8. Power

AC 85~265V 50/60Hz free voltage

2. Attention

For the efficient and safe use, please carefully read and be fully aware of the following details before using this product.

It is strictly forbidden to use this product for any other purpose of use or to attempt to make any alteration on this product.

2-1. Attention for installation

- Please keep it out of wet places.
- Do not set it up near vibration & impulse, high temperature and humidity.
Keep it out of the direct rays of the sun. Set it up where there is less dust, and Keep it out of direct air including salt and ion.
- Do not use when there is inflammable gas or heavy machinery, and smog.
- Ground earth-terminal (⊕).
- Make wire separately from power system wiring and noise wiring.
- Make sure the use of 4 line sealed cable as a sensor cable.
Too long cable leads to measurement error due to wiring resistance (around 10meters).

2-2. Attention for use

During calibration, Do not input free-load state and real-weight load until it becomes stable. Pressing Enter Key in unstable condition leads to calibration error.

Do not press any Key in use at one's discretion. Please refer to 7. Setting-up mode for the function and method of Key.

3. Specification

- Available sensor : Pressure sensor, resistance displacement meter, Voltage & current output sensor
- Upper limit Display : -19999 ~ +99999
- A/D Converter : 16bit, 100 times/sec
- D/A Converter : 12bit
- Temperature Characteristic (Amp Characteristic)
 - Zero : 0.5 μ V/ $^{\circ}$ C
 - Span : 50ppm/ $^{\circ}$ C
- Front Panel
 - Measured value display: 7 segment 5 Digit, Character Height 14mm
 - Status display : Red LED 3 pcs
 - Key Switch : 4 pcs
- Output
 - Comparison output: Upper limit(HI), Lower limit(LO), Normal(OK) Output
Contact Capacity – AC 250V 0.5A/ DC 50V 1A
 - Analog Output : DC 0~10V (4~20mA available by internal operation)
- Temperature Range: -10 $^{\circ}$ C ~ 60 $^{\circ}$ C, less than 80% RH (no dewing.)
- External dimension : 96 × 48 × 128 mm (W × H × D)
- Panel cutting size : 91.5 × 44.5 mm
- Weight : About 800g
- Power Supply : AC 85~265V 50/60Hz free voltage
- Option : RS232C (OP-02), RS485 (OP-03)

4. Front Panel

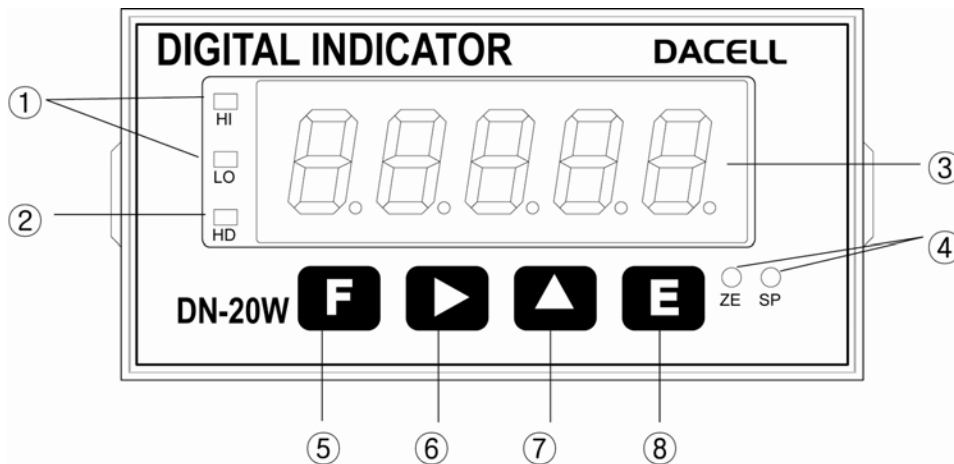

① HI, LO Indication LED

: Hi or LO LED will be lighted when measured value exceeds the setting value.

② HOLD indication LED

: This LED will be lighted when the measured value is on Hold.

③ Measured value Indication

: It indicates the measured value and each setting value.

④ ZERO/SPAN setting up VR

: It is used when ZERO and SPAN calibration of Analog output (DC 0 ~ 10V or 4 ~ 20mA) is carried out.

⑤ **F**
ZERO

Measuring Mode : Once this Key is pressed for more than 1 second, the current measuring value will be Zero (0) and the Analog output will be 0V (4mA) as well.

SET-UP Mode : Once this is pressed on the Function Set-up Mode, you will return to the measuring mode.

⑥ **▶**
LO

Measuring Mode : Once this Key is pressed, the lower limit setting value will be displayed and this value also can be changed.

SET-UP Mode : The location of row for the number flickering can be moved.

⑦ **▲**
HI

Measuring Mode : Once this Key is pressed, the upper limit setting value will be displayed and the value can be changed.

SET-UP Mode : The flickering number will be increased by 1 and 1.

⑧ **E**
HOLD

Measuring Mode : Once this Key is pressed, HOLD will be selected and once this key is pressed again, HOLD will be cancelled.

SET-UP Mode : Save each set-up value.

5. Rear Panel

Please check the location of terminal and its use. While the projected button is being pressed, please insert the cable into the lower hole completely. As soon as you release the button, the connection will be completed. At the point, please slightly pull the cable and check whether the cable is come off or not.

(The most suitable cable is Φ 0.5~1. Linking cable must be brazing or used with 1 terminal)

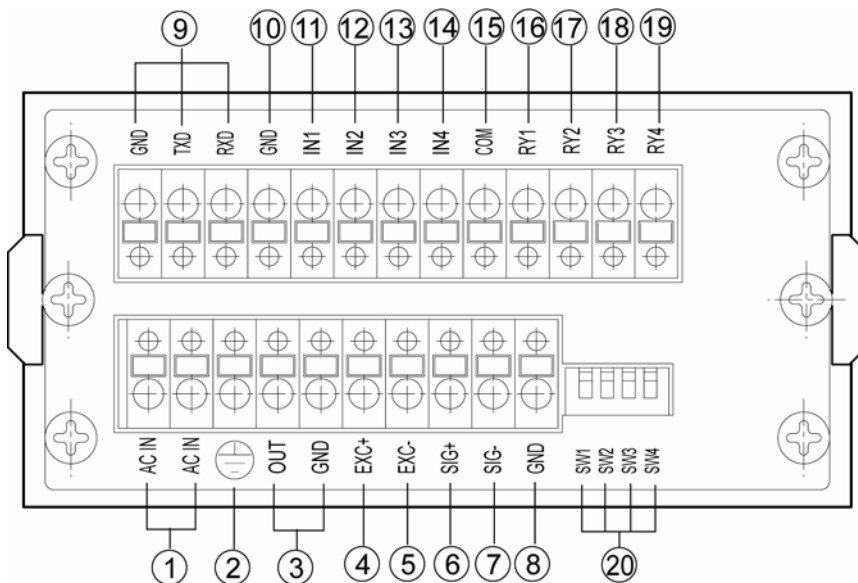

- ① AC IN : Main Power Supply Wiring Terminal
- ②  : Ground Terminal (as an independent ground connection.)
- ③ OUT : Analog (DC 0 ~10V/DC 4 ~ 20mA) Output Terminal
- ④ EXC+ : Sensor Supply Voltage + Connection Terminal
- ⑤ EXC- : Sensor Supply Voltage - Connection Terminal
- ⑥ SIG+ : Sensor Output Signal + Connection Terminal
- ⑦ SIG- : Sensor Output Signal - Connection Terminal
- ⑧ GND : SHIELD connection terminal of sensor
- ⑨ GND, TXD, RXD : RS232C SERIAL INTERFACE (RS485 : TXD → TX+, RXD → TX-)
- ⑩ GND : External Input Common Terminal
- ⑪ IN1 : External HOLD Input Terminal
- ⑫ IN2 : External ZERO Input Terminal
- ⑬ IN3 : External printer signal Input Terminal (when PT-100 use)
- ⑭ IN4 : No use

- ⑮ COM : RELAY Output Common Terminal
- ⑯ RY1 : RELAY 1(Lower Limit) Output Terminal
- ⑰ RY2 : RELAY2 (Upper Limit) Output Terminal
- ⑱ RY3 : RELAY3(Normal) Output Terminal (OK)
- ⑲ RY4 : RELAY 4 Output Terminal
- ⑳ Sensor supply voltage & sensor input select switch

	Sensor supply voltage setting		Sensor input signal setting	
	10V	24V	Voltage type	Current type
SW1	ON	OFF	–	–
SW2	OFF	ON	–	–
SW3	–	–	OFF	ON

◀Attention▶

1. When wiring, please pull out the power plug. (Main power supply)
2. Please use the thick cable for ground terminal (⊕) so that you can avoid any trouble due to the impulse voltage or surge. If possible, please keep it as an independent ground.
(This must be used in the area with heavy noise. If the ground is made with other device, it will be affected by noise.)
3. Please check the function of the terminal before you do the wiring so that you can prevent any malfunction in advance.
4. Manufacture will be relieved of its responsibility for any damage or injury due to the disassembly and alteration made without any agreement. Also, no A/S will be made.

6. Wiring Diagram

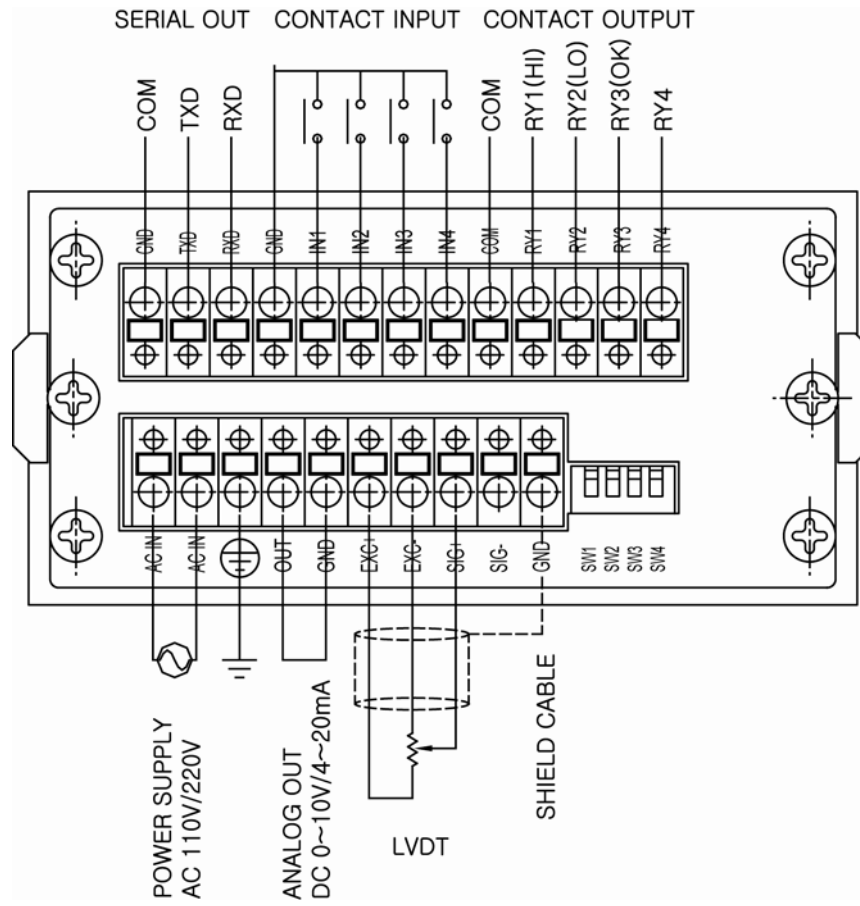

<Wiring Diagram>

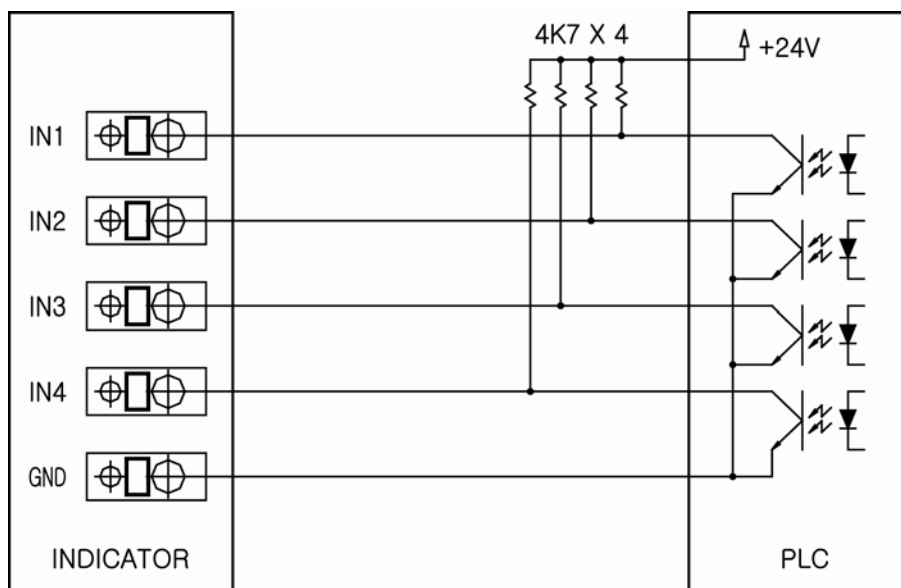

<Example - External Input PLC Connection>

7. 구성요소 및 기능

7-1. 순서도

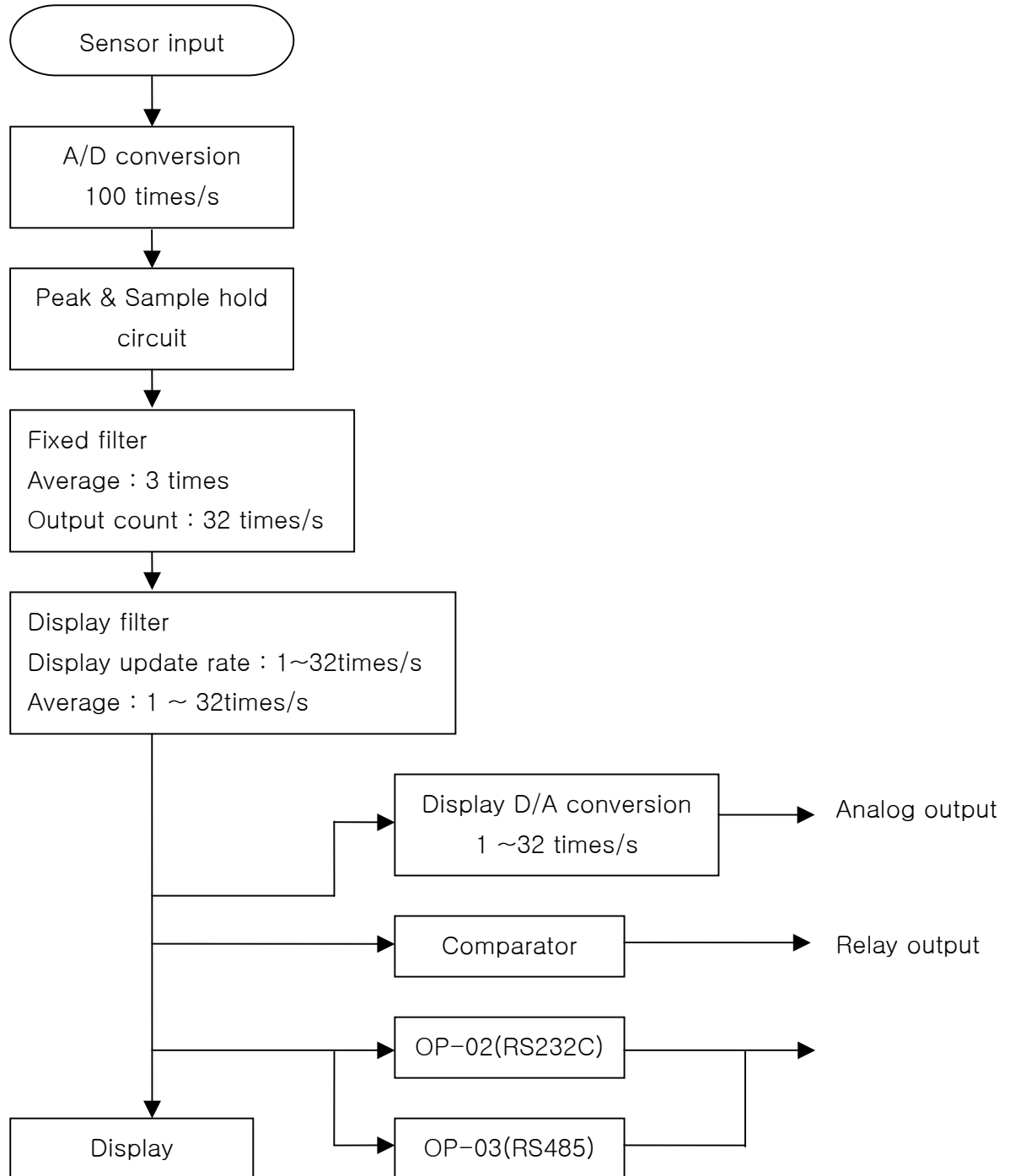

7-2. How to use Hold mode

Hold mode is largely divided into Peak Hold and Sample Hold. Please select Analog, Digital or Display Hold as per your purpose of use (Hi or Low Speed)

To input Hold, you can use Hold key on the front panel or external input. For the operation method, please refer to the drawing below.

1) Peak Hold : To Hold the maximum value among the measured values.

Peak hold mode : It is a high-speed Peak hold. It is to hold and display the maximum value of (+) direction.

Absolute peak hold mode : It is to hold and display the the maximum value of the absolute value (+/-).

2) Sample hold : It is to hold and display the value at the time of Hold signal input among the measured values.

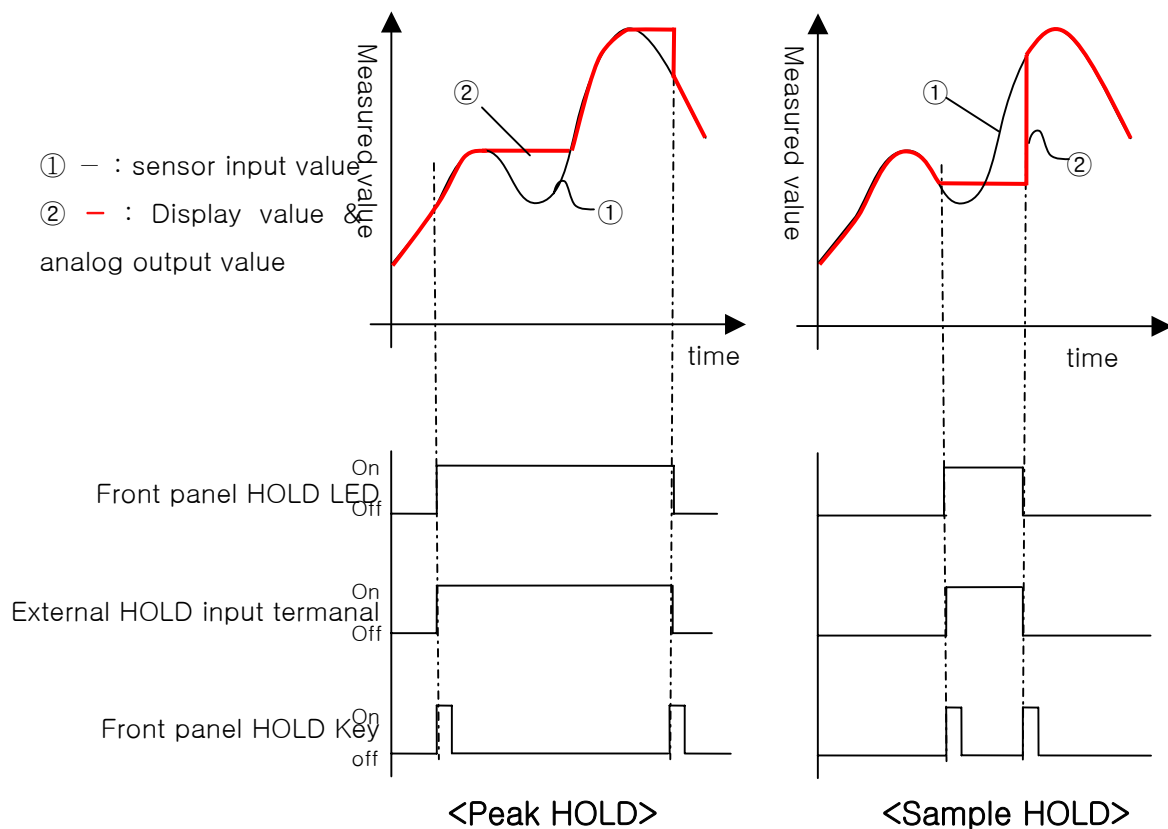

7-3. How to use comparison output function

For comparison output function, there are 3 different modes such as Decision, High limit, Low limit. It displays through the relay of rear panel comparing each setup value.

On High limit and Low limit mode, Hysteresis can be used.

To set up upper limit (High) and lower limit(Low), please use the key on the front panel.

- 1) Decision mode :
Measured Value \leq Lower limit setup value \Rightarrow RY1 ON (LO)
Measured Value \geq Upper limit setup value \Rightarrow RY2 ON (HI)
Lower limit setup value $<$ Measured value $<$ Upper limit setup value \Rightarrow RY3 ON(OK)
- 2) High limit mode :
Measured Value \geq RY1 setup value \Rightarrow RY1 ON
Measured Value \geq RY2 setup value \Rightarrow RY2 ON
Measured Value \geq RY3 setup value \Rightarrow RY3 ON
Measured Value \geq RY4 setup value \Rightarrow RY4 ON
Measured Value $<$ RY1 setup value – Hysteresis value \Rightarrow RY1 OFF
Measured Value $<$ RY2 setup value – Hysteresis value \Rightarrow RY2 OFF
Measured Value $<$ RY3 setup value – Hysteresis value \Rightarrow RY3 OFF
Measured Value $<$ RY4 setup value – Hysteresis value \Rightarrow RY4 OFF
- 3) Low limit mode :
Measured Value \leq RY1 setup value \Rightarrow RY1 ON
Measured Value \leq RY2 setup value \Rightarrow RY2 ON
Measured Value \leq RY3 setup value \Rightarrow RY3 ON
Measured Value \leq RY4 setup value \Rightarrow RY4 ON
Measured Value $>$ RY1 setup value + Hysteresis value \Rightarrow RY1 OFF
Measured Value $>$ RY2 setup value + Hysteresis value \Rightarrow RY2 OFF
Measured Value $>$ RY3 setup value + Hysteresis value \Rightarrow RY3 OFF
Measured Value $>$ RY4 setup value + Hysteresis value \Rightarrow RY4 OFF
- 4) Low & High limit mode
Measured Value \leq RY1 setup value \Rightarrow RY1 ON
Measured Value \leq RY2 setup value \Rightarrow RY2 ON
Measured Value \geq RY3 setup value \Rightarrow RY3 ON
Measured Value \geq RY4 setup value \Rightarrow RY4 ON
Measured Value $>$ RY1 setup value + Hysteresis value \Rightarrow RY1 OFF
Measured Value $>$ RY2 setup value + Hysteresis value \Rightarrow RY2 OFF
Measured Value $<$ RY3 setup value – Hysteresis value \Rightarrow RY3 OFF
Measured Value $<$ RY4 setup value – Hysteresis value \Rightarrow RY4 OFF

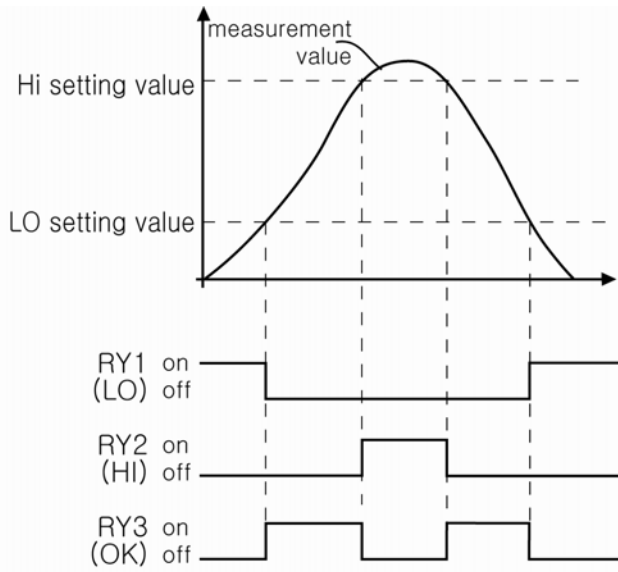

<Decision mode>

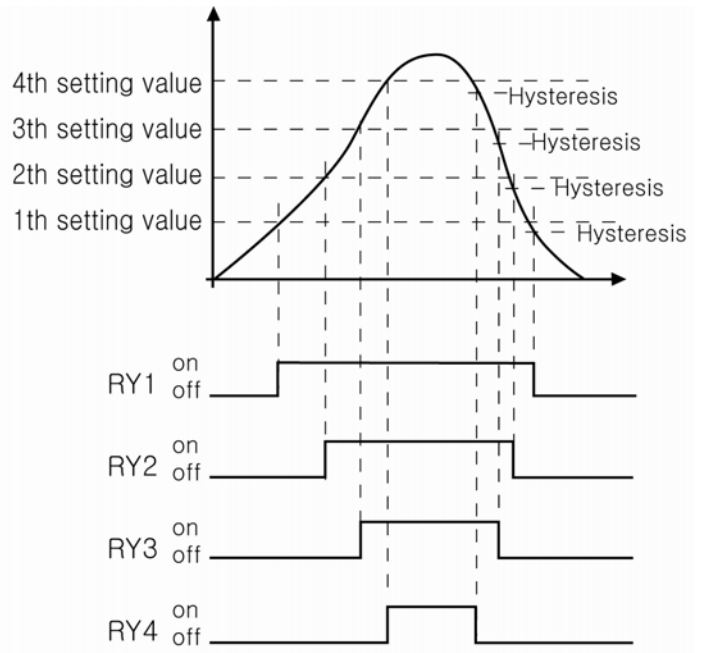

<High limit mode>

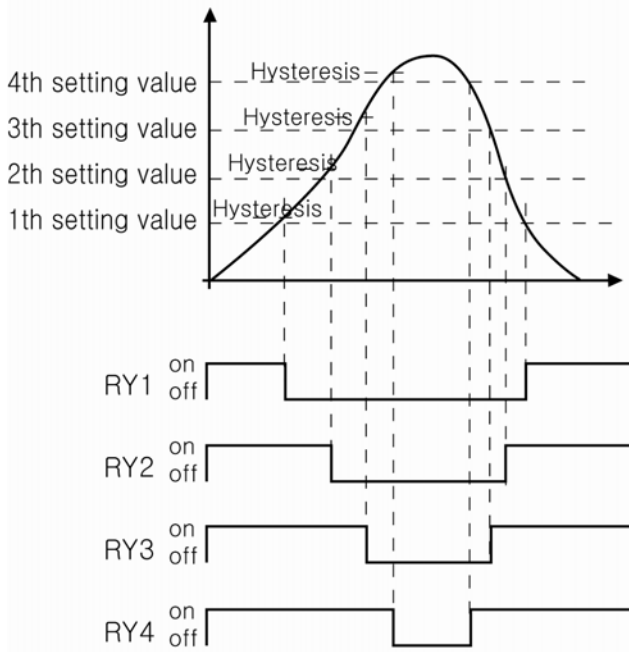

<Low limit mode>

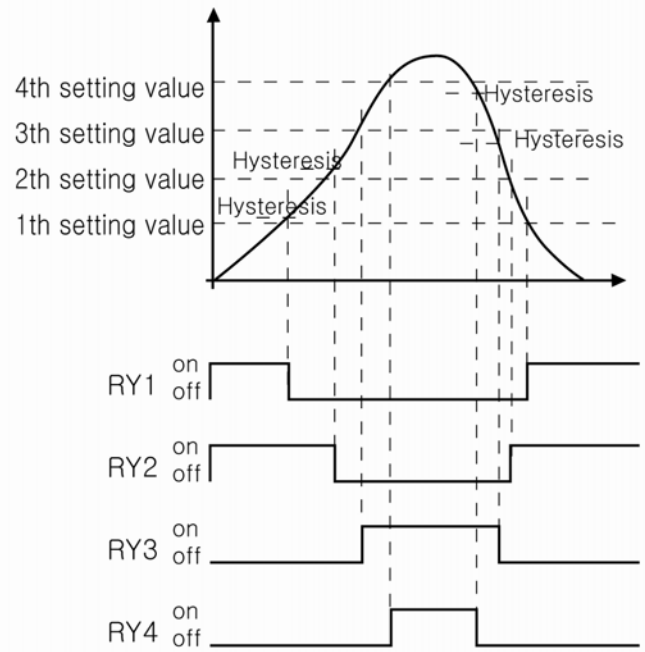

<Low & High limit mode>

8. Setting Modes

8-1. Types of Setting mode & Set-up

For setting mode, there are 3 different types of mode such as Function mode, Digital calibration mode, Actual load calibration mode.

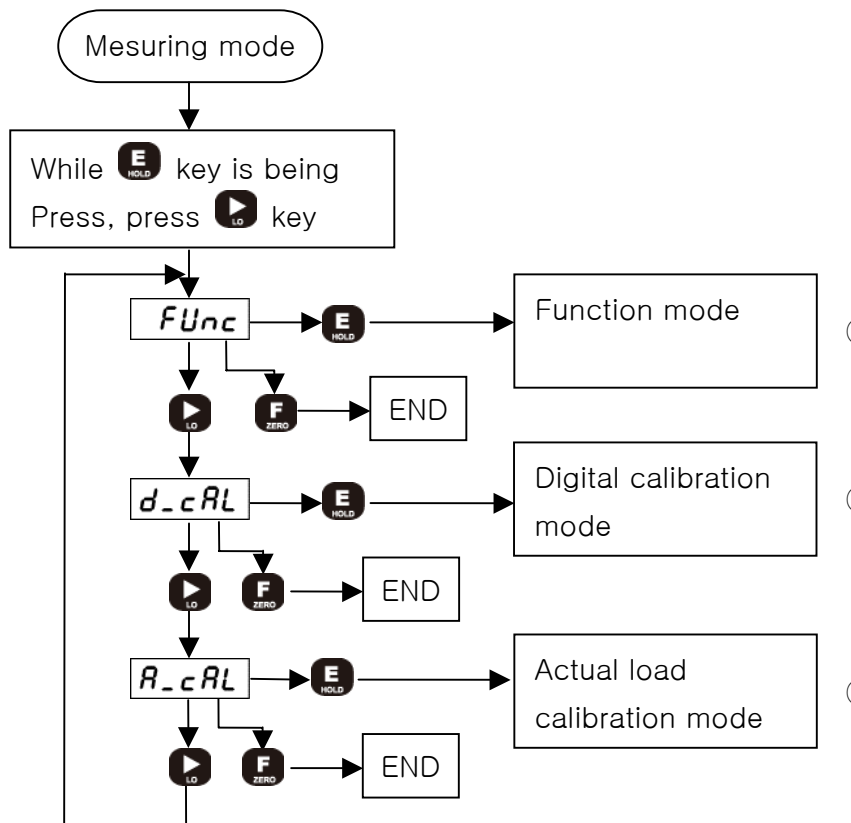

- ① Function mode
Access to each function setup mode. Please refer 8-2 function mode.
- ② Digital calibration mode
It is to calibrate into the sensor's output value. No need to prepare for the actual load (stand weight). Please refer 8-3 how to calibrate.
- ③ Actual load calibration mode
It is to calibrate by adding the actual load (standard weight or the load you know). Please refer 8-4 how to calibrate.

8-2. Function mode

1) How to set function.

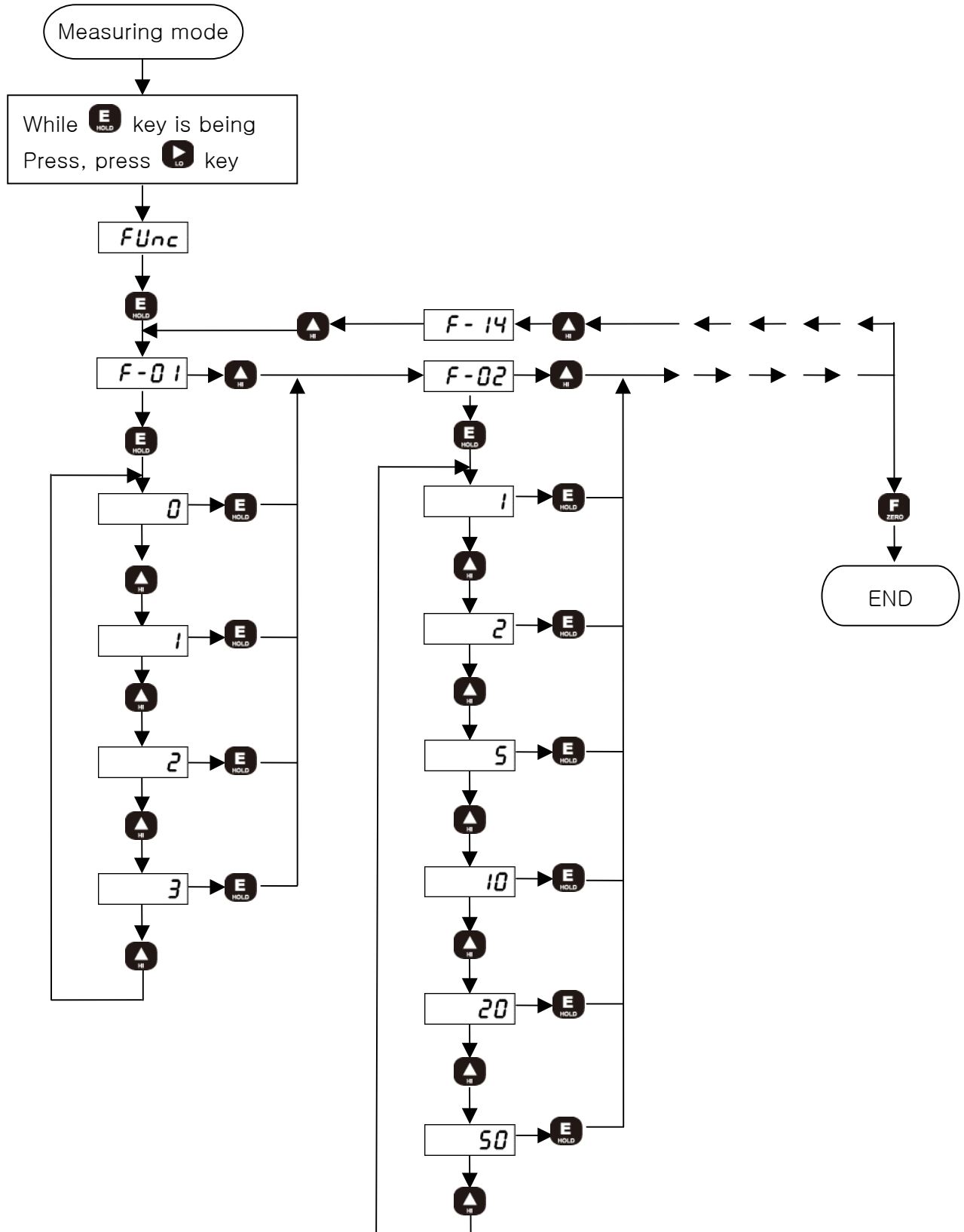

2) How to set RELAY data

① Decision mode (Decision mode: mode 0)

② Limit mode (Low & High limit mode: mode 1 ~ 3)

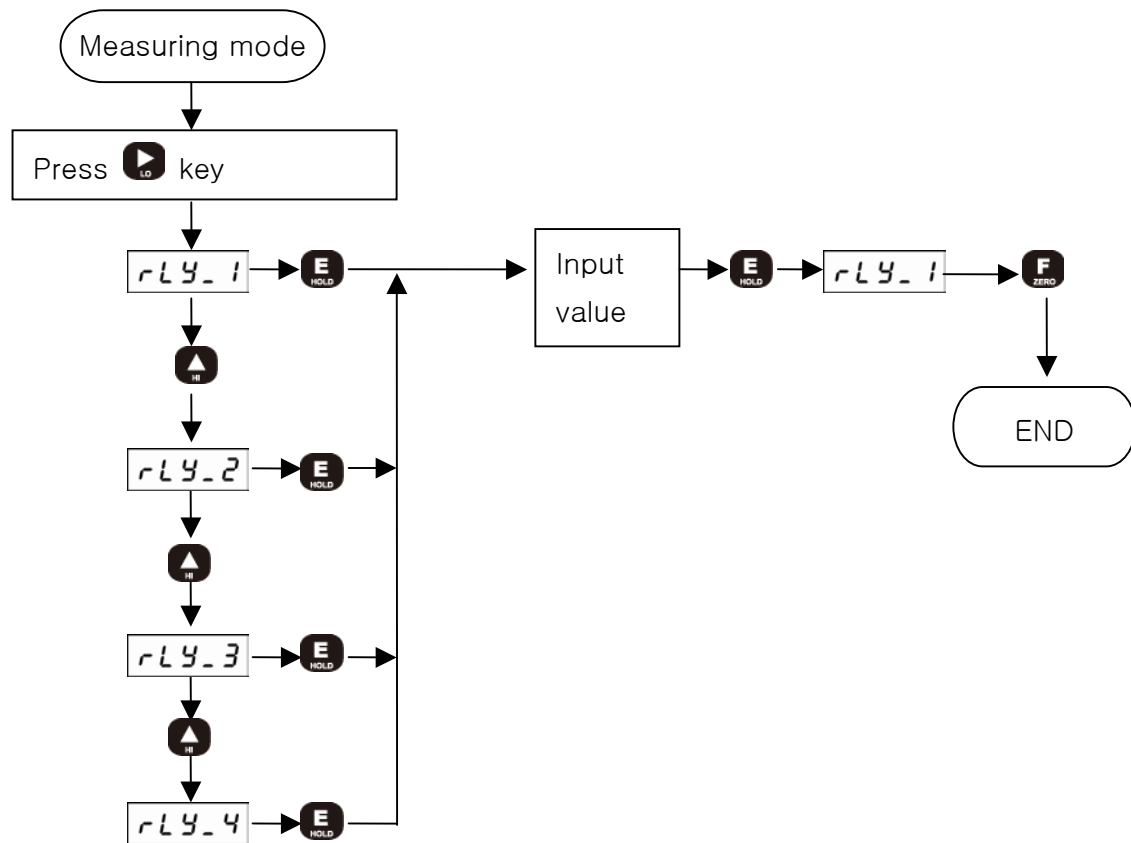

Function mode list

Name	Function	Setting	The standard set-up value
F-01	Decimal point	0, 1, 2, 3	1
F-02	Division	1, 2, 5, 10, 20, 50	1
F-03	Display filter	0, 4, 8, 16, 32	16
F-04	Hold mode	Sample hold, Peak hold, Absolute peak hold	Peak hold
F-05	Comparison mode	Decision, High limit, Low limit, Low&High limit	Decision
F-06	Hysteresis	0 ~ 99	0
F-07	DAC zero	-19999 ~ +99999	0
F-08	DAC capacity	-19999 ~ +99999	10000
F-09	ID Number	0 ~ 32	0
F-10	Baud rate & PRINT	2400, 4800, 9600, 19200, print	9600
F-11	Auto zero tracking	0 ~ 99	0
F-12	Auto zero tracking time	0.0 ~ 5.0 sec	0.0
F-14	Key disabling	Zero key, Lo key, Hi key, Hold key	0000

F-01. Decimal point (Decimal point set up)

(Standard setup value: 1)

Display data	Setting
0	00000 : No decimal point
1	0000.0 : One decimal place
2	000.00 : Two decimal places
3	00.000 : Three decimal places

F-02. Division (Minimum display unit set up)

(Standard setup value: 1)

Display data	Setting
1	Displayed In 1 (0, 1, 2, 3, 4 …….)
2	Displayed in 2 (0, 2, 4, 6, 8 …….)
5	Displayed in 5 (0, 5, 10, 15 …….)
10	Displayed in 10 (0, 10, 20, 30 …….)
20	Displayed in 20 (0, 20, 40, 60 …….)
50	Displayed in 50 (0, 50, 100, 150 …….)

F-03. Display filter (Display speed set up)

(Standard setup value: 16)

Display data	Setting
0	No filter
4	Average time 1/8 sec
8	Average time 1/4 sec
16	Average time 1/2 sec
32	Average time 1 sec

F-04. Hold mode

(Standard setup value: 1)

Display data	Setting
0	Sample Hold : To hold the display value at the time of Hold signal input.
1	Peak Hold (+) : To hold the maximum value of display values during Hold signal input.
2	Absolute Peak Hold(+/-) : To hold the maximum absolute value of display values during Hold signal input.

F-05. Comparison mode (Comparison output mode set up)

(Standard setup value: 0)

Display data	Setting
0	Decision mode : Relay RY1(Lo), RY2(Hi), RY3(Ok) Output
1	High limit mode : Relay RY1, RY2, RY3, RY4 output
2	Low limit mode : Relay RY1, RY2, RY3, RY4 output
3	Low & High limit mode : Relay RY1, RY2, RY3, RY4 output

F-06. Hysteresis

(Standard setup value: 00)

Display data	Setting
00 }	00 : Hysteresis – not used
99	01 ~99 : Hysteresis – used (Decision mode is not applied)

F-07. DAC zero (Analog Outupt zero set up)

(Standard setup value: 0)

Display data	Setting
-19999~+99999	Analog output zero value set-up

F-08. DAC capacity (Analog Outupt value set up)

(Standard setup value: 10000)

Display data	Setting																																								
-19999 } +99999	Analog output capacity set-up <Setting value & output>																																								
	<table border="1"> <thead> <tr> <th colspan="2">Setting value</th> <th colspan="2">Voltage output(0~10V)</th> <th colspan="2">Current output(4~20mA)</th> </tr> <tr> <th>ZERO</th> <th>CAPACITY</th> <th>Display value</th> <th>output</th> <th>Display value</th> <th>output</th> </tr> </thead> <tbody> <tr> <td rowspan="3">0</td> <td rowspan="3">+10000</td> <td>-10000</td> <td>0V</td> <td>-10000</td> <td>4mA</td> </tr> <tr> <td>0</td> <td>0V</td> <td>0</td> <td>4mA</td> </tr> <tr> <td>+10000</td> <td>+10V</td> <td>+10000</td> <td>20mA</td> </tr> <tr> <td rowspan="3">0</td> <td rowspan="3">-10000</td> <td>-10000</td> <td>+10V</td> <td>-10000</td> <td>20mA</td> </tr> <tr> <td>0</td> <td>0V</td> <td>0</td> <td>4mA</td> </tr> <tr> <td>+10000</td> <td>0V</td> <td>+10000</td> <td>4mA</td> </tr> </tbody> </table>	Setting value		Voltage output(0~10V)		Current output(4~20mA)		ZERO	CAPACITY	Display value	output	Display value	output	0	+10000	-10000	0V	-10000	4mA	0	0V	0	4mA	+10000	+10V	+10000	20mA	0	-10000	-10000	+10V	-10000	20mA	0	0V	0	4mA	+10000	0V	+10000	4mA
Setting value		Voltage output(0~10V)		Current output(4~20mA)																																					
ZERO	CAPACITY	Display value	output	Display value	output																																				
0	+10000	-10000	0V	-10000	4mA																																				
		0	0V	0	4mA																																				
		+10000	+10V	+10000	20mA																																				
0	-10000	-10000	+10V	-10000	20mA																																				
		0	0V	0	4mA																																				
		+10000	0V	+10000	4mA																																				

F-09. ID Number (Communication Device Number set up)

(Standard setup value: 00)

Display data	Setting
00 } 32	00 : Device number is not set-up(Stream mode:always transmit data) 01 ~32 : Device number is set-up(Command mode:Transmit data by command)

F-10. Baud rate & Print (Communication Speed set up)

(Standard setup value: 9.60)

Display data	Setting	Stream mode	Command mode
2.40	2400 bps	○	○
4.80	4800 bps	○	○
9.60	9600 bps	○	○
19.20	19200 bps	○	X
PRINT	PRINT DATA OUT (PT-100)	-	-

F-11. Auto zero tracking (Auto zero operation range set up)

(Standard setup value: 00)

Display data	Setting
00 } 99	00 : Auto zero is not used 01 ~99 : Set up the operation range of auto zero

F-12. Auto zero tracking time (Auto Zero tracking time set up)

(Standard setup value: 0.0)

Display data	Setting
00 } 5.0	0.0 : Auto zero is not used 0.1 ~5.0 : set up the auto zero operation time (0.1 ~ 5.0 sec)

F-13. Key disabling (Front key locking set up)

(Standard setup value: 0000)

Display data	Setting
0 0 0 0 ↑ ↑ ↑ ←	Hold key Lock (1), Release (0) Hi key Lock (1), Release (0) Lo key Lock (1), Release (0) Zero key Lock (1), Release (0) <Set-up example>

1001 : Zero & Hold key Lock, Hi and Lo key Release

8-3. Digital calibration (Calibration by sensor output value)

It will be able to calibration with output type and rated capacity setting.

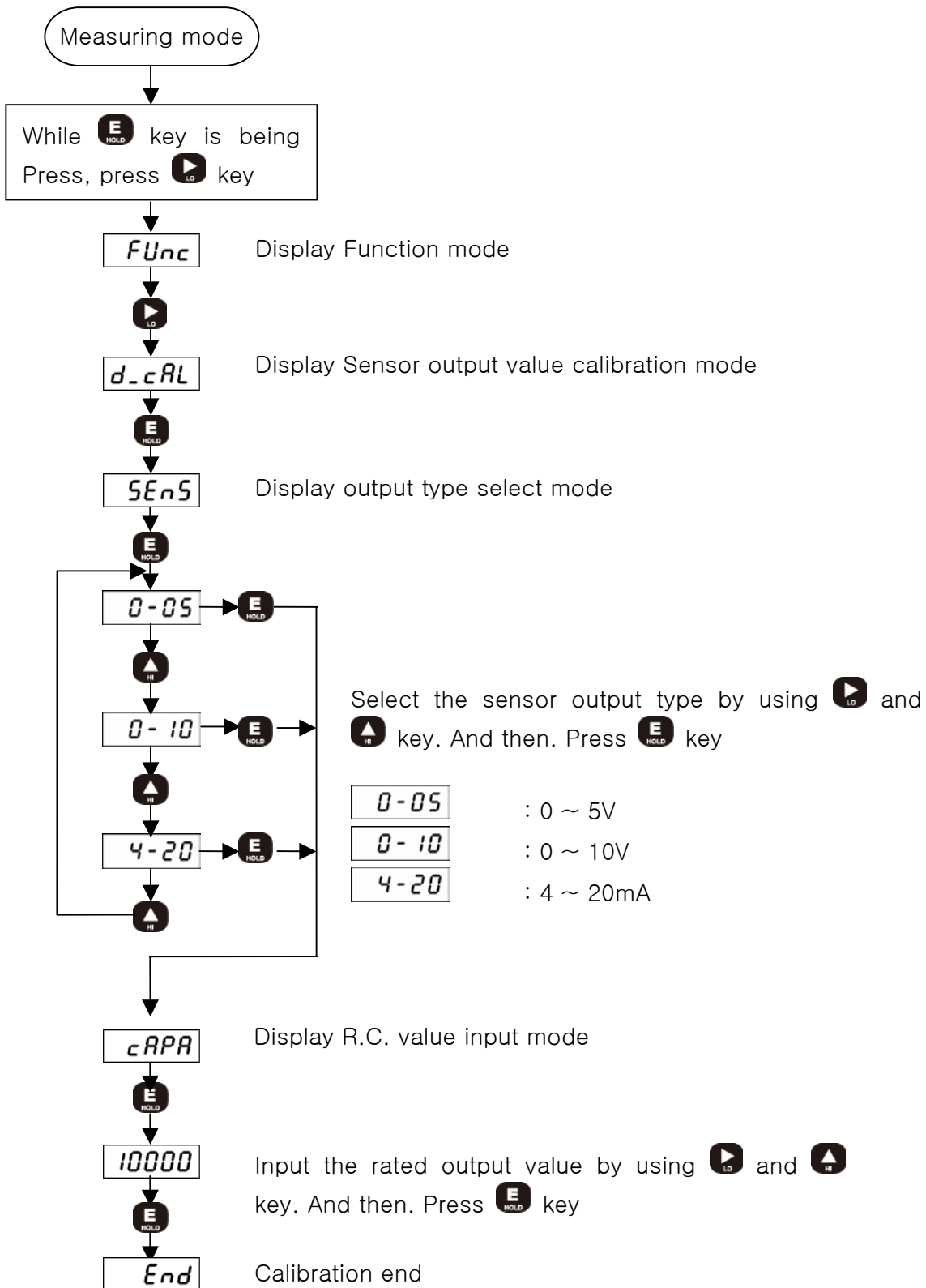

8-4. Actual load calibration

This is a calibration method by adding actual load on the sensor. Standard weight is needed.

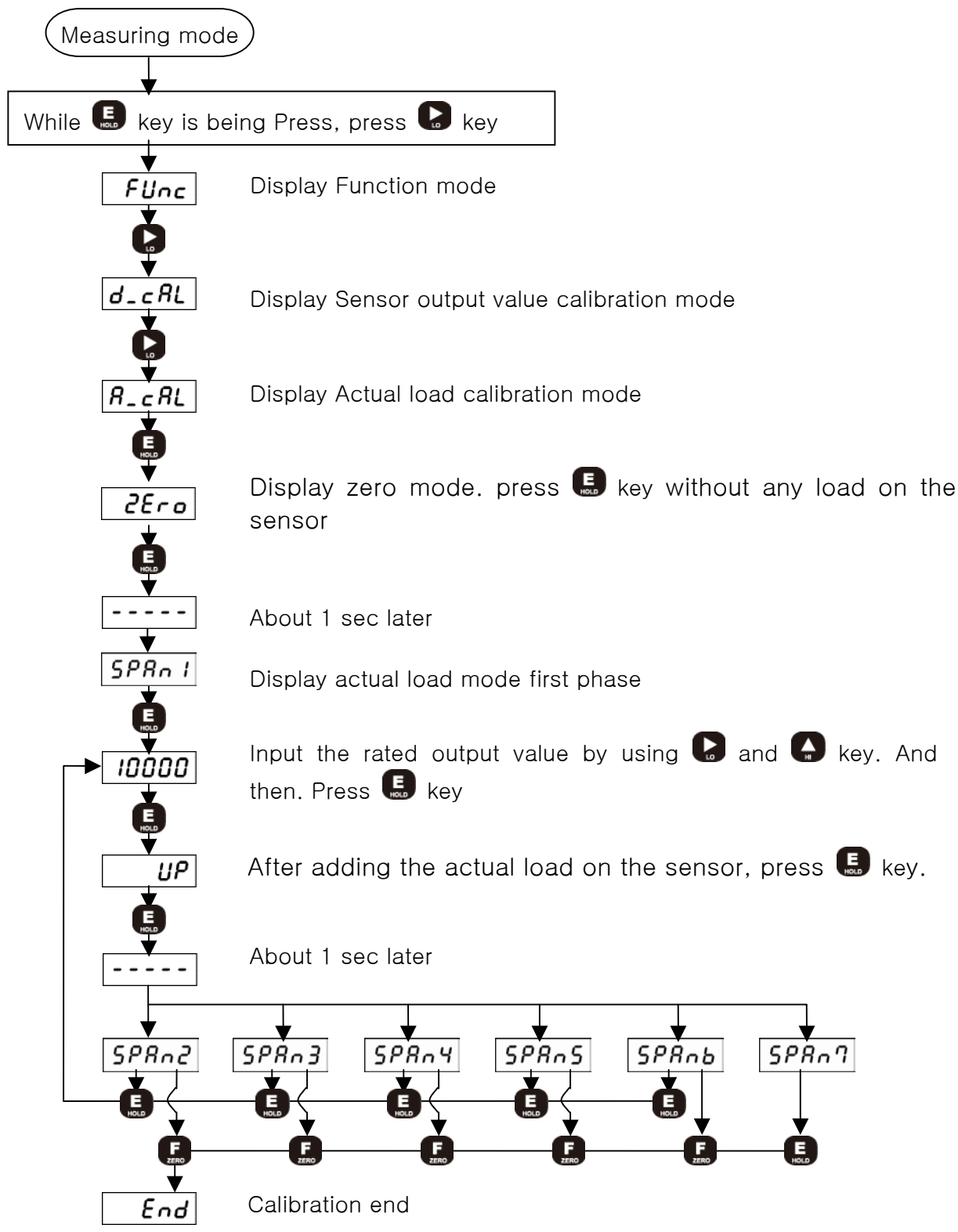

8-6. Lock Set-up

You can prevent any accidental operation due to the unnecessary key control by Lock set-up. After finishing calibration, it is recommended to set the Lock.

At the first stage, please start while the power is OFF.

Related Function when Lock is set : Function related to calibration

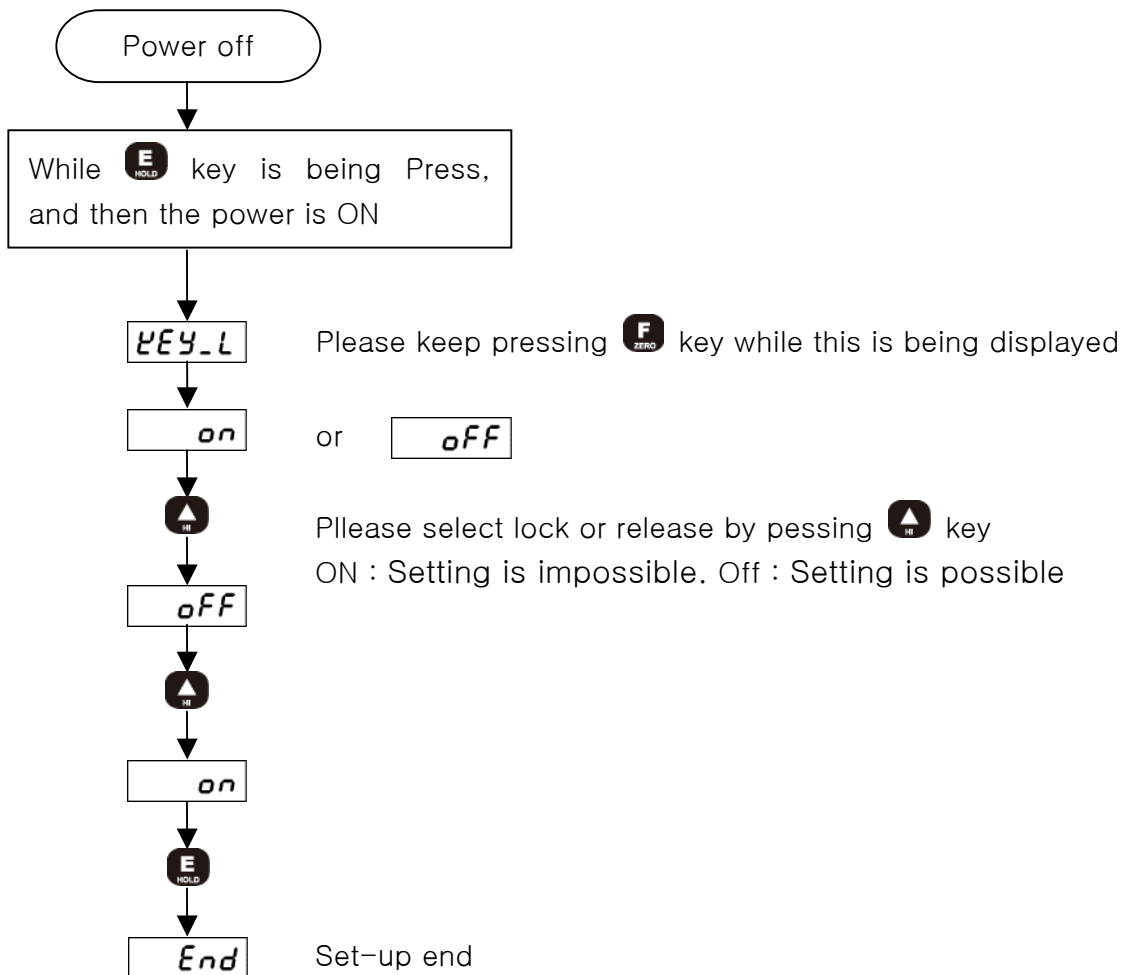

9. OPTION

#Option-02 (RS232C)

Since RS232C Interface is very sensitive of electric noise. So please do the wiring from AC Power and electric wires separately. Also you must use the shield cable always.

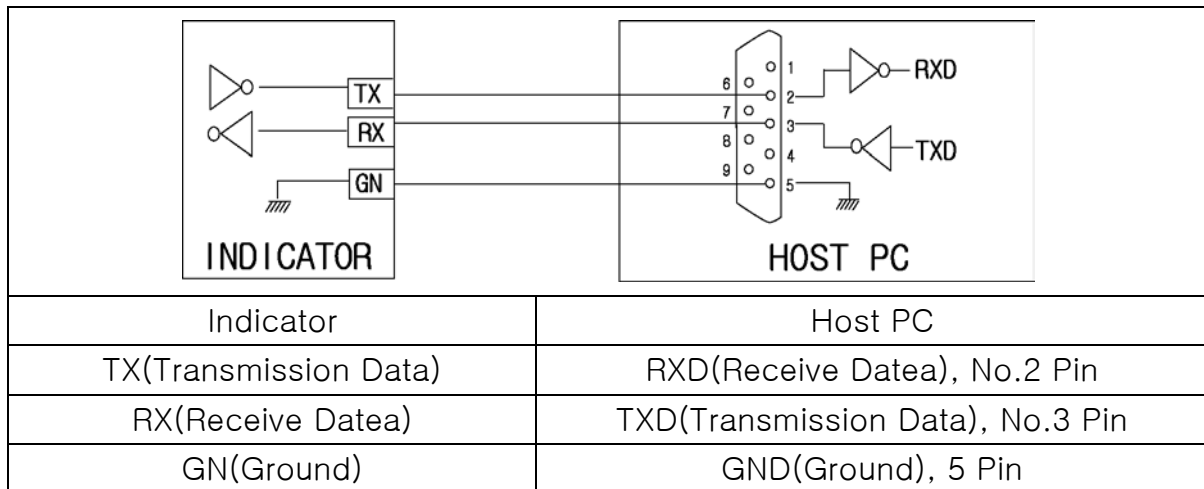

1. TYPE : EIA-232C
2. Method : Half-duplex, asynchronous method.
3. Baud-rate : Select one of 2400, 4800, 9600, 19200bps
4. Parity : No Parity
5. Data bit : 8 bit
6. Stop bit : 1 bit
7. Stream mode (Ex. Data +1234.5 transmission)

CODE	BYTE1	BYTE2	BYTE3	BYTE4	BYTE5	BYTE6	BYTE7	BYTE8
ASCII	S	T	,	N	T	,	+	0
HEX	53H	54H	2CH	4EH	54H	2CH	2BH	30H

CODE	BYTE9	BYTE10	BYTE11	BYTE12	BYTE13	BYTE14	BYTE15	BYTE16
ASCII	1	2	3	4	.	5	CR	LF
HEX	31H	32H	33H	34H	2EH	35H	0DH	0AH

1) BYTE1, BYTE2

- . DATA Stable : S T . DATA Unstable : U S
- . DATA OVERFLOW: O L . DATA UNDERFLOW : U L

2) BYTE3 ~ BYTE6 : fixed character (, N T ,)

3) BYTE7 ~ BYTE14 : DATA 8 BYTE(including +/-)

- 4) BYTE15 : CARRIAGE RETURN
- 5) BYTE16 : LINE FEED

8. Command mode

OP-03 : Refer to RS485

#Option-03 (RS485)

Since RS485 Interface is very sensitive of electric noise. So please do the wiring from AC Power and electric wires separately. Also you must use the shield cable always.

1. TYPE : RS485
2. Method : Half-duplex, asynchronous method.
3. Baud-rate : Select one of 2400, 4800, 9600bps
4. Parity : No Parity
5. Data bit : 8 bit
6. Stop bit : 1 bit

Please set up the device No. referring to INDICATOR Manual.
(Can set up from 1 to 32 channels.)

7. Command form (PC → INDICATOR)

CODE	BYTE1	BYTE2	BYTE3	BYTE4	BYTE5
ASCII	I	D	0	1	P
HEX	49H	44H	30H	31H	50H

- 1) BYTE1, BYTE2 : Fixed character (ID)
- 2) BYTE3, BYTE4 : device number (1 ~ 32)
- 3) BYTE5 : command order (P, H, R, Z)

8. Command chart

Command		
ASCII	HEX	
P	50H	Transmit the current value of order equipment.
H	48H	Hold for order equipment.
R	52H	Release hold for order equipment.
Z	5AH	Operate the current value of order equipment as ZERO.

9. Transmission DATA form (INDICATOR → PC)

CODE	BYTE1	BYTE2	BYTE3	BYTE4	BYTE5	BYTE6	BYTE7	BYTE8
ASCII	I	D	0	0	1	,	+	0
HEX	53H	54H	30H	30H	31H	2CH	2BH	30H

CODE	BYTE9	BYTE10	BYTE11	BYTE12	BYTE13	BYTE14	BYTE15	BYTE16
ASCII	1	2	3	4	.	5	CR	LF
HEX	31H	32H	33H	34H	2EH	35H	0DH	0AH

- 1) BYTE1, BYTE2 : Fixed character (ID)
- 2) BYTE3 ~ BYTE5 : Device number (1 ~ 32)
- 3) BYTE6 : Fixed character (,)
- 4) BYTE7~BYTE14 : DATA 8byte (including +/-)
- 5) BYTE15 : CARRIAGE RETURN
- 6) BYTE16 : LINE FEED