

Dynamic Amplifier

>Model DN-AM120



- Waterproof amplifier: Strain gauge sensor
- Built-in single step filtering function
- Easy to adjust zero and span by volume
- Response frequency characteristic: DC ~ 20kHz
- Protection class: IP66, EN60529

>Model DN-AM130



- This product is Dynamic Strain Amplifier of DC voltage control.
- Low price and waterproof type.
- One touch auto zero
- Real weight calibration

>SPECIFICATIONS

Specifications	Accuracy
Bridge voltage	Constant voltage DC 5V, 10V
Application bridge resistance	100Ω ~ 1kΩ
Rated output	Voltage 0 ~ 10V (Load resistance more than 200Ω) Current 4 ~ 20mA (Load resistance less than 300Ω)
Zero adjustment ranger	10%, 10 Rotation
Stability (temp. characteristic)	1500 Multiplier
S/N rate	51dB
Frequency response	DC ~ 20kHz (-3dB)
Low Pass Filter	10Hz, 100Hz, 1kHz, Pass
Nonlinearity	0.02% F.S
Usage temperature range	-10°C ~ 60°C
Humidity	IP66, EN60529
Supply power	DC24V

>SPECIFICATIONS

Specifications	Accuracy
Bridge voltage	Constant voltage DC 5V
Application bridge resistance	100Ω ~ 1kΩ
Rated output	Voltage 2 ~ 10V (Load resistance more than 200Ω) Current 4 ~ 20mA (Load resistance less than 300Ω)
Zero adjustment ranger	50% F.S
Stability (temp. characteristic)	1500 Multiplier
A/D Converter	12 bit, 100Hz
D/A Converter	12 bit, 100Hz
Low Pass Filter	100Hz
Nonlinearity	0.02% F.S
Usage temperature range	-10°C ~ 60°C
Humidity	IP66, EN60529
Supply power	DC24V

>DIMENSIONS

unit:mm

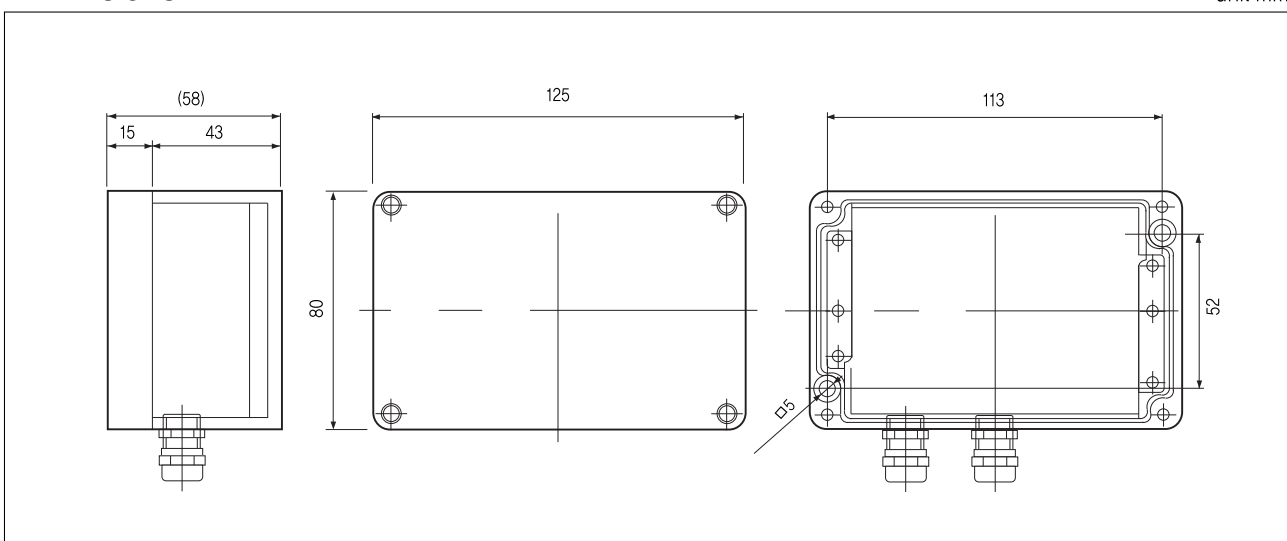

★Specifications are subject to change without notice.