

MODEL : DN-AM310 _____
DYNAMIC STRAIN AMPLIFIER

USER'S MANUAL

DACELL CO.,LTD.

Address: 681-1, Cheoksan-Ri, Nami-Myeon, Cheongweon-Gun,
Chung-Buk, 363-810 Korea

TEL: 82-43-260-2242

FAX: 82-43-260-2245

<http://www.dacell.com>

E-Mail: dana@danaloadcell.com

CONTENTS

1. FOREWORD	2
2. SPECIFICATION	3
3. COMPOSITION	6
3-1. FRONT PANEL	6
3-2. BACK PANAL	6
3-3. DESCRIPTION	7
4. HOW TO OPERATE	9
4-1. POWER CONNECTION.....	9
4-2. SENSOR CONNECTION	9
4-3. INPUT HIGH LEVEL VOLTAGE.....	9
4-4. NOTES FOR SELECTING SENSOR CABLE	10
4-5. NOTES FOR DYNAMIC MEASUREMENT	10
4-6. NOTES FOR STATIC MEASUREMENT.....	11
4-7. Output CONNECTION.....	11
4-8. CONTROLLING PROPER SENSOR VOLTAGE.....	11
4-9. BRIDGE BALANCE.....	12
4-10. GAIN CONTROL	12
4-11. FILTER CONTROL.....	13

1. FOREWORD



Dynamic Strain Amplifier DN-AM310 is composed as the following features.

- This device amplifies minute voltage signals of strain gauge type sensor or all types of transducer to display and output as in voltage.
- Shunt CAL feature is installed.
- Electronic Auto Zero Balance method is used for Zero Span.
- It is designed to install on standard 19" Sub rack.

2. SPECIFICATION

- ① Measurement marks : 1CH / EA
- ② Measuring method : Deflection Method
- ③ Working Gauge : 120Ω, 350Ω
- ④ Gauge rate : 2.00
- ⑤ Bridge voltage (B.V/V) : DC 1V, 2V, 5V, 7.5V, 10V
- ⑥ Measuring range
- | Bridge Voltage | Measuring range |
|----------------|-----------------|
| 10V..... | 2000 μstrain |
| 5V..... | 4000 μstrain |
| 2V..... | 10000 μstrain |
- ⑦ Zero adjustment range
- Automatic equilibrium control (Auto) : Push button
- adjustment range: $\text{input} \times \text{EXC} \times \text{1st Gain} \leq 5\text{V}$ (absolute value)
 - Example : If EXC 10V, 1st Gain X500,
Zero adjustment range = $\text{input} \times 10\text{V} \times 500 \leq 5\text{V}$
Input $\leq 1\text{mV/V}$
 - Extent : $\pm 10\text{mV}$ max
 - Time : About 1 senond.
 - Back up : semi-permanent
- Hand-operated fine control (Zero): Volume
- Adjustment range : $\pm 100\text{mV}$
- ⑧ Output
- OUT1 : DC $\pm 10\text{V}$ @10mA max
- OUT2 : DC $\pm 10\text{V}$ @100mA max
- ⑨ Non-linearity : $\pm 0.01\%$ F.S
- ⑩ Calibration (Shunt CAL)
- Extent : 0.1% F.S
- 1.0mV/V : 2000μstrain
- 0.1mV/V : 200μstrain

⑪ Sensitivity adjustment (GAIN)

X1, X10, X100, X400, X1000 within $\pm 0.1\%$ at error each point

(SPAN) X1 ~ X10 continuous variableness

(FINE) X1 ~ X0.9 continuous reduction

⑫ S/N rate (Input conversion numerical value): more than 54dB (1kHz)

CMRR (Input conversion numerical value): more than 100dB (1kHz)

⑬ Response frequency characteristic

50kHz max @ 1st Gain X1000

⑭ Low Pass Filter

(L.P.F) Frequency : 10, 100, 1K, 10K, WB 5 stages

About decrease : within -6dB/oct

⑮ Temperature range for use

0 ~ $+60^\circ\text{C}$

⑯ Effect by temperature change

Zero drift: within $\pm 1 \mu\text{strain}/^\circ\text{C}$

Sensitivity change: $\pm 0.03\% \text{ F.S.}/^\circ\text{C}$

⑰ Effect by electric power change (About $\pm 10\%$ change in supply voltage)

Zero drift: within $\pm 0.05\% \text{ F.S.}$

Sensitivity change: within $\pm 0.05\% \text{ F.S.}$

⑱ MONITOR : Digital Voltage Display

Over 10V will be displayed in 10.00 (increased or decreased in each 0.01)

Less 10V will be displayed in 0.000 (increased or decreased in each 0.001)

Voltage on OUT1 will be displayed in Digital.

⑲ Supply Voltage

AC100/220V $\pm 10\%$ 60Hz

⑳ External Size and Weight

128.4 (H) \times 43.2 (W) \times 198 (D) mm

800g

㉑ OPTION

Current output : 4 ~ 20mA out (OUT2)

3. Composition

3-1. Front Panel

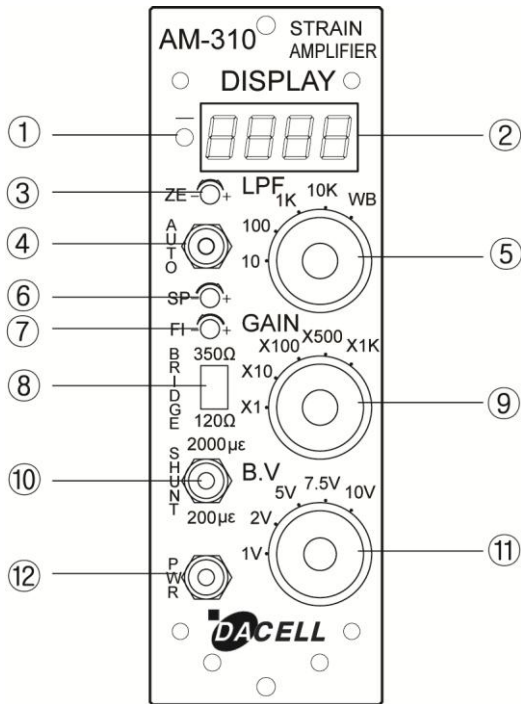

- ① Symbol (-) display
- ② Voltage display
- ③ Zero hand-operated control volume
- ④ Zero auto control switch
- ⑤ L.P.F switch
- ⑥ GAIN control volume
- ⑦ GAIN fine control volume
- ⑧ Bridge voltage selecting switch
- ⑨ GAIN selecting switch
- ⑩ CAL Strain value switch
- ⑪ Bridge Voltage selecting switch
- ⑫ Power switch

3-2. Back Panel

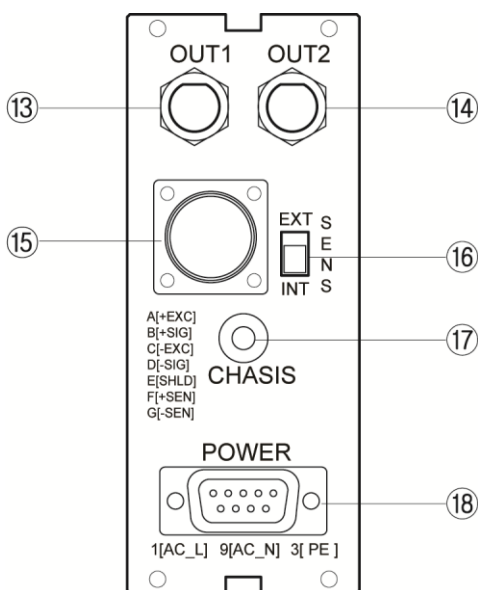

- ⑬ Low-current output (more than 2kΩ load)
- ⑭ High-current output (more than 200Ω load)
- ⑮ Sensor input connector
- ⑯ Bridge Voltage sense selecting switch(6-wire circuit)
- ⑰ Case earth terminal
- ⑱ Power input connector

3-3. Description

① Symbol (-) display

This symbol lamp will be lighted when the output voltage is become less than 0V.

② Voltage display

Output voltage is displayed as in 4 Digit -7 Segment LED.

When output voltage is over 10V or below -10V, it will be displayed as +/- 10.00 and the rest section will be displayed as in +/- 9.000V.

③ Zero Hand-operated control volume

It is a volume to control the offset of residual quantity after finishing the auto zero control.

Control range is within $\pm 100\text{mV}$.

④ Zero auto control switch

Use this switch to carry out auto zero control.

When this auto switch is pressed, "Auto" will appear on the LED and then zero will be set.

⑤ L.P.F switch

It is a switch is to control the frequency of the active filter.

The frequency of Cut-off can be controlled as in 10Hz, 100Hz, 1kHz, 10kHz, and WB(Wide-band).

⑥ GAIN control volume

It is a volume to control GAIN and it can be continuously controlled from X1 up to X10 times.

⑦ GAIN fine control volume

It is a volume for the fine control of GAIN. It can be continuously controlled from X1 up to X0.9 times.

⑧ Bridge voltage selecting switch

This switch is to select the bridge resistance while you are doing bridge calibration.

⑨ GAIN selecting switch

It is the switch to control GAIN and it can be controlled as in X1, X10, X100, X400, X1000 times.

⑩ CAL Strain value switch

It is a shunt switch to calibrate the bridge in two different types – 2000 μ and 200 μ strain.

⑪ Bridge voltage selecting switch

This switch is to select the bridge supply voltage.

You can make your selection for the supply voltage among DC 1V, 2V, 5V, 7.5V, 10V.

⑫ Power switch

This switch is to supply power to Amplifier.

⑬ High-current output (more than 200 Ω load) connector

It is the final output signal of Amplifier and also high-current output.

You can use this on more than 200 Ω load.

⑭ Low-current output (more than 2k Ω load) connector

It is the final output signal of Amplifier and also low-current output.

You can use this more than 2k Ω load.

⑮ Sensor input connector

You can use Strain gauge type sensor as well as Potentiometer Voltage input.

⑯ Bridge voltage sense selecting switch (6-wire circuit)

When select by EXT mode as switch to compensate bridge voltage by Cable's resistance change, bridge voltage by Cable length change moves automatically and is corrected.

⑰ Case earth terminal

Connects and uses with outside ground in case of biographical environment with noise is bad.

⑱ Power input connector

This connector is to supply external AC power.

4. How to operate

4-1. Power connection

- ① Please only use the exclusive AC code (3-tube) for the power cord. When AC is not grounded, please make the connection by using the ground connector which is located on the backside of lamp.
- ② Please check the AC power selecting switch and then supply power to the device. If the lamp is not lighted, please check the fuse and power selecting switch.

4-2. Sensor connection

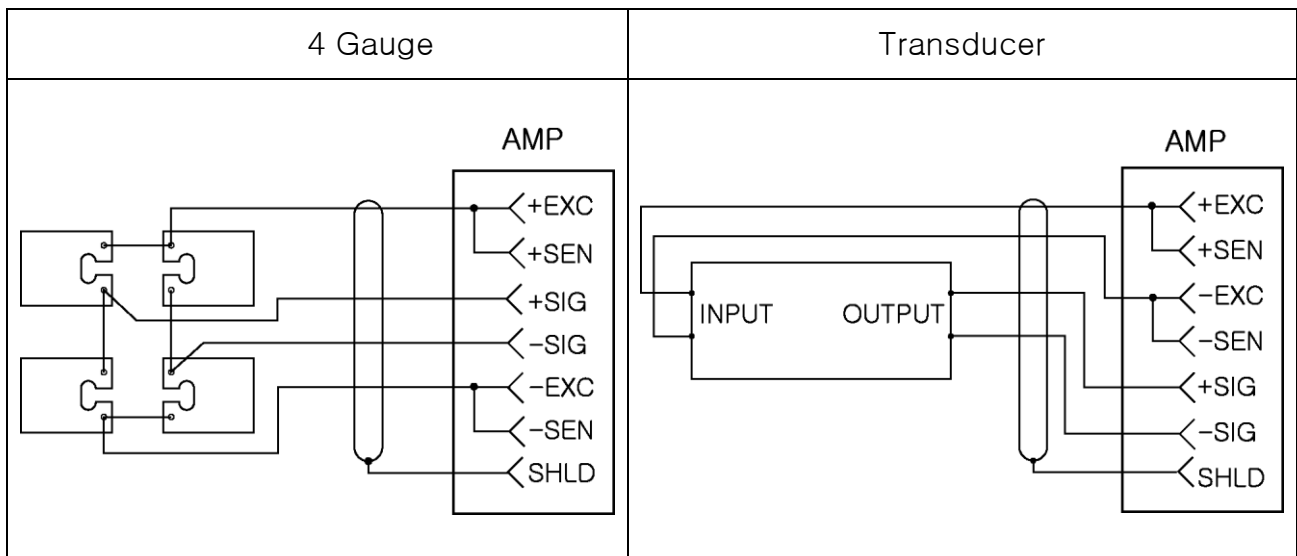

Full Bridge Connection

4-3. High Level Voltage Input

This device can measure the signal that inputted in DC (DCDT, High level, Thermocouple etc).

For the measurement, following conditions should be satisfied.

- ① On Common mode, the amp input should be as $\pm 10V$. Please be careful since when over $\pm 10V$ is inputted, the signal source will be cut off.
- ② When Thermocouple temperature sensor is used, an error in measurement can

be occurred since the temperature–electromotive force might be generated on the commissure between the connector pin of amplifier and thermocouple lead wire. Therefore, you should do the cold junction compensation or you should carry out the measurement in the place where without such a big temperature change.

③ The input stage of amplifier are “+SIG”, “-SIG”. Since their minimum input current is originated by this input impedance, it should be over 50nA to carry out the measurement.

4-4. Notes for selecting sensor cable

The each space for selecting sensor cable should be:

- ① electrically isolated.
- ② Cable resistance should be small.
- ③ The cable resistance of the internal lines should be regular.
- ④ It is better to use the shield cable.

4-5. Notes for Dynamic measurement

Strain gauge or Transducer (located at the end of the measurement lead cable) is exposed to various electric devices and equipment and also receive the analogue frequency (50kHz, 60kHz) noise from the line power. Therefore, please carry out the following procedures to minimize this kind of happening.

- ① Please prepare for the shield cable. (If the shield cable cannot be ready, please make the lead cable as shortest as possible.)
- ② The shield cable should be connected to the ground and input connector.
- ③ The cable resistance of the internal cables should be regular.
- ④ It's better to use the shield cable.
- ⑤ All wires should be built in the clean environment for the measurement. (Please avoid using transformer, motors, relay and high voltage cable where the magnetic field can be easily generated. If it is necessary to use one of them, please use any structure for the protection.)

⑥ If you use a long wire, please use a balanced leading line so that you can minimize the noise.

4-6. Notes for Static measurement

You must make sure that the cable resistance between each gauge lead wire is regular. If it is not, the measurement value can be changed by the surrounding temperature. Please pay your special attention for this point.

Please carry out the following procedures.

① You must use 3-line for Quarter Bridge.

② To minimize the effect by the temperature change, it is ideal to put all the used lead wire in the same wire bunch.

③ To build the precise data when you use a long wire, please do the compensation considering the resistance of lead.

(Example : The thickness, length of the wire and its proper resistance etc)

4-7. Output connection

Output $\pm 10V$ can read the voltage output value as in oscilloscope, volt meter and A/D board on the output connector.

4-8. Controlling proper sensor voltage

Sometimes when you do the stress analysis, the high proper voltage to the active gauge might be required. When the proper voltage is high, the output will be big so that you do not have to amplify too much. But when the high voltage is applied to the gauge with low resistance, an error in measurement can be occurred since the joule heat might be generated on the gauge. So the most suitable condition should be found since the resistance on the gauge and proper voltage are very important. In addition to the gauge with high resistance (over 350Ω) or the long and wide gauge, you can increase the proper voltage at the place where the heat-sinking (aluminum etc) easily can be done.

Please avoid increasing the proper voltage with the gauge below 120Ω or at the place where the heat-sinking cannot be done such as plastic.

Normally the gauge proper voltage should be 10%~100% of the recommended

voltage from the gauge.

Maximum Metallic (foil) gauge can be normally 50% ~ 75% for the stability and good S/N (signal to noise).

Exclusive voltage should be applied for the semi conductive gauge.

To control the sensor proper voltage of the amplifier, please turn the bridge voltage switch.

4-9. Bridge balance

Generally, when the bridge balance is too much out, you cannot carry out the measurement for the wide range since the measurement value will be clipped. Also you should compensate the bridge balance since a damage can be made on hardware.

For the compensation, please press the Auto switch on the front side of amplifier then "Auto" will be lighted on the voltage LED to calibrate the balance automatically.

Please control the volume for the rest output voltage to set Zero.

4-10. GAIN control

Firstly, please turn the gain switch in a clockwise to set (X1, X10, X100, X400, X1000) gain.

Or you can turn 10-turn volume so that you can control gain (X1 ~ X10).

The gain noise is originated by input voltage. So when the input voltage is increased, the noise will be increased accordingly. So please set the gain according to the size of sensor.

While you are carrying out stress analysis, please compensate as following so that you can get the precise information. (in case 1 active gauge is used)

$$V_{out} = V_B \times A \times \frac{K}{4} \times \mu\epsilon \times 10^{-6}$$

Vout : Output voltage of amplifier

V^B : Bridge proper voltage

A : Amplifier gain

K : Gauge factor

For the Transducer, please use the following formula by using the output value you know.

EX) 2mV/V

$$V_{out} = V_B \times A \times K \times 10^{-3}$$

V_{out} : Output voltage of amplifier when the maximum output of transducer is inputted

V^B : Bridge proper voltage

A : Amplifier gain

K : Output sensitivity of transducer (mv/V)

For shunt compensation, error can be occurred by wiring, bridge resistance or proper voltage while stress analysis is being done. So shunt compensation is very important when you set the amplifier gain. Also when you use the analogue transducer (force, torque and pressure etc), please fully understand the size of transducer and the form of output so that you can select correct amplifier gain accordingly.

4-11. Filter control

As standard, DN-AM310 has 2 pole standard low-pass filter installed. Controllable switch is located on the front side of amplifier and the signal noise is 10Hz, 100Hz, 1kHz, 10kHz. Wide-band can be controlled by band pass. This cut-off frequency is normally originated in 30% (-3dB) of output. For control, please turn the rotary selector switch located on the front side of the amplifier.

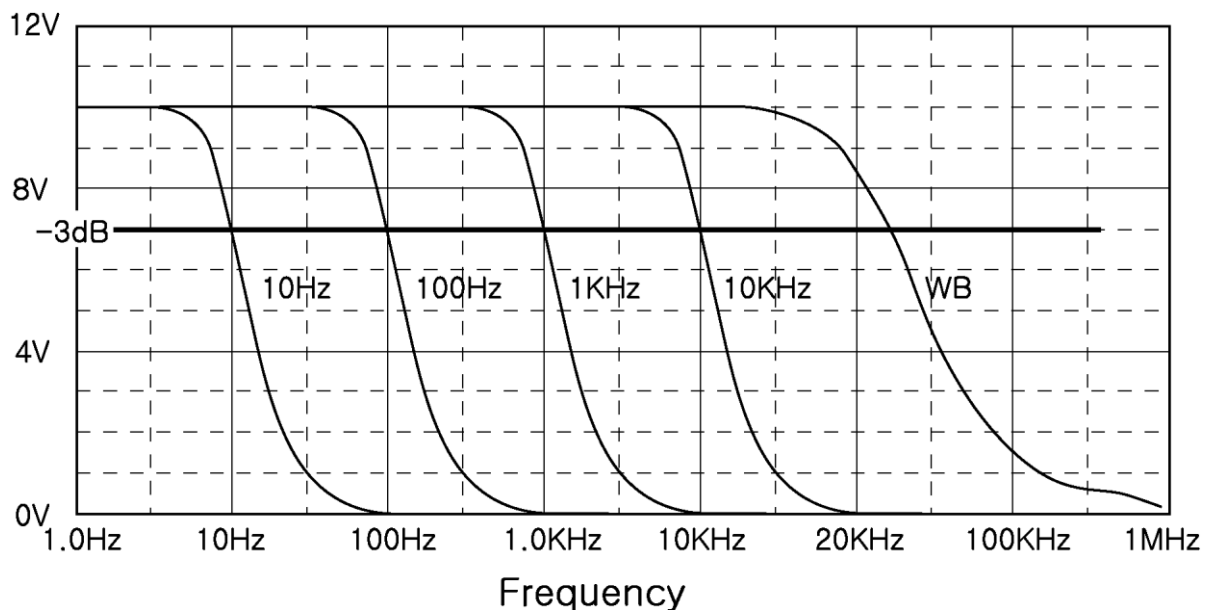

L.P.F Characteristic

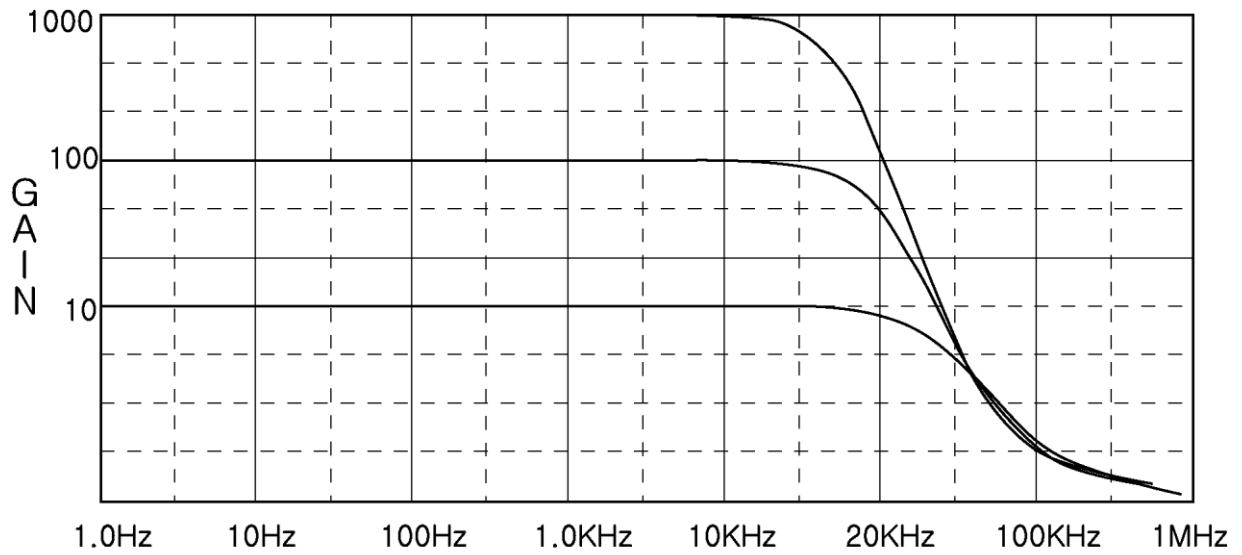

Frequency
GAIN Band Width Characteristic