

MODEL: DN-FGA _____
FORCE GAUGE

Operating Manual



DACELL CO., LTD.

Address: 681-1, Cheoksan-ri, Nami-myeon, Cheongwon-gun, Chungbuk

TEL: +82-43-260-2242

FAX: +82-43-260-2245

Website: <http://www.dacell.com>

E-Mail: info@dacell.com

Table of Contents

1. Special Features	2
1-1. Method of Conversion	2
1-2. Method of Calibration	2
1-3. HOLD Function	2
1-4. Comparison Output	2
1-5. Data Back-up	2
1-6. Electric Source	2
2. Notes	3
2-1. Notes before Use.....	3
2-2. Notes during Use	3
3. Specifications	4
4. Front Panel	5
5 Connection Diagram of Connector	7
6. Components and Functions	8
6-1. How to use the Hold Mode	8
6-2. How to use the Compare Output Function	9
7. Setting Mode	12
7-1. Function Mode (Function Sett-up)	12
7-2. Actual Load Calibration	18
7-3. Lockdown Settings.....	20
8. Communications (USB)	21
8-1. Stream Mode	21
8-2. Command Mode	22
8-3. Memo Data Transmission	23
9. Product Check	24

1. Special Features

Thank you for using our product. If you find any problem during use, refer to this Operation Manual for the appropriate action or call us.

This product is an indicator that amplifies the micro voltage signal of various sensors and indicates in digital; it is mainly used to measure the physical quantity of the load cell, pressure sensor, displacement sensor, and torque sensor of a strain gauge, etc., and has the following special features:

1-1. Method of Conversion

This product uses a 16-bit high speed A/D conversion device that detects the input signal of a sensor at a speed of 100 times/second.

Using a 12-bit D/A conversion device, it outputs the indication value in analog format.

1-2. Method of Calibration

It adopts two kinds of methods: the calibration method by the actual load (standard weight), and by the rate output of the sensor.

1-3. Hold Function

It is usable by selecting the Peak Hold and the Sample Hold.

1-4. Comparison Output

Setting of the highest value and the lowest value is possible; the comparison output is done by an open collector signal.

1-5. Data Back-up

All setting values are memorized, and the flash memory and input data can be saved even in a power outage, thus, resetting is not needed.

1-6. Electric Source

Nickel hydrogen (NimH), Charging Adapter (DC 9V)

2. Notes

For performance and safe use of this product, please be aware of the following notes. In particular, do not use this instrument for any other purpose than was it is intended for, and do not remodel it arbitrarily.

2-1. Notes before Use

- Key is activated by pressing lightly, so do not press it too hard.
- When washing it, do not use inflammables.
- Do not let it get wet.
- Avoid placing it in extreme temperatures.
- Do not install it near high voltage or electrical noise.
- Store it in a dry place.
- Do not use it near strong sunlight or where it is overly dusty.

3. Specifications

- A/D Transducer: 16-bit, 100 times/sec
 - D/A Transducer: 12-bit
 - Indication of Measuring Value: 5 Digit LCD (indicating forward/reverse direction)
 - Indication of Measuring Unit: Kgf, N, lbf, ozf
 - Condition indicating LED: Indication of charge and compare output condition
 - Compare Output: High, Low, Good
 - Analog Output: DC +/-1V
 - Communication Output: USB
 - Range of using temperature: -10°C to 40°C, 80% RH and below (in locations without due condensation phenomenon)
 - Weight: Approximately 600g
 - Electric Source: Nickel hydrogen (NimH), Chargeable Adapter (DC 9V)
 - Continuous Use Life: Approximately 40 hours
 - Charging Time: Approximately 8 hours
 - Option OP-01: USB cable, OP-02 :Analog out and open collector connector.
- Standard components

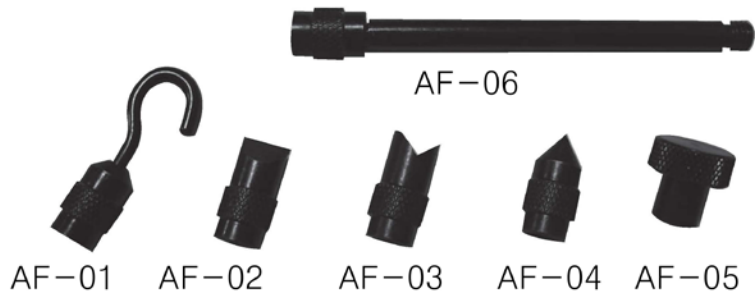

- Handy case



4. Front Panel

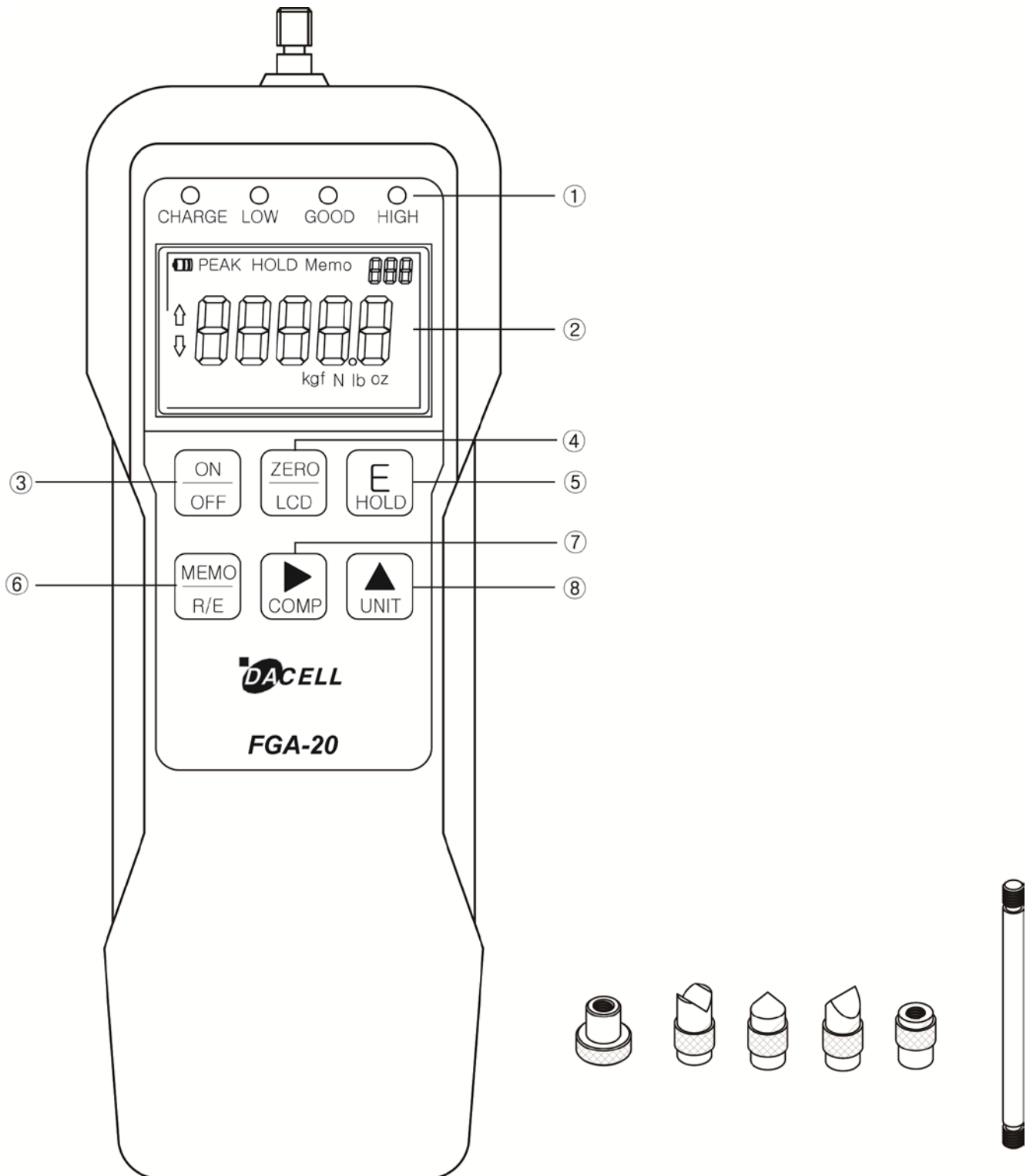

① Condition indicating LED

When each condition is as it should be, the corresponding LED lights up.

Charge indicators (during charging: red; after charging is complete: green)

② Measurement Value Indicating LCD

 (Battery): This indicates battery condition; when it needs charging, it blinks.

In order to prevent it from losing all charge, it turns off after a certain amount of time.

PEAK: This indicates peak hold condition.

HOLD: This indicates sample hold condition.

Memo: This indicates the point to save the measured value (max. 500).

↑↓ (arrows): ↑: pull (symbol: +); ↓: compression (symbol: -)

Kgf, N, lb, oz: They indicate the current measurement units, which are converted in accordance by the unit.



③

Power ON/OFF Key: Press it for 3 seconds, and the power turns on.



④

Measuring Mode: Press the key briefly, and the current measured value becomes ZERO (0), and Analog output also becomes 0V. Press the key for a longer time, and the LCD window converts to forward/reverse direction.

Setting mode: Press the in the function setting mode, and it returns to the measuring mode.



⑤

Measuring mode: Press the key, and HOLD moves. Press the key again, and HOLD releases.

Setting mode: This saves each setting value.



⑥

Press the key briefly, and the current measured value is saved. Press the key for a longer time, and the saved value can be read or deleted.



⑦

Measuring Mode: Press the key, and the compare output value can be set.

Setting Mode: This moves the position of the blinking number line.



⑧

Measuring Mode: Press the key, and the measuring unit and measured value are converted.

Setting Mode: This increases the numerical value of the blinking number.

5. Connection Diagram of Connector

① LOAD CELL connector

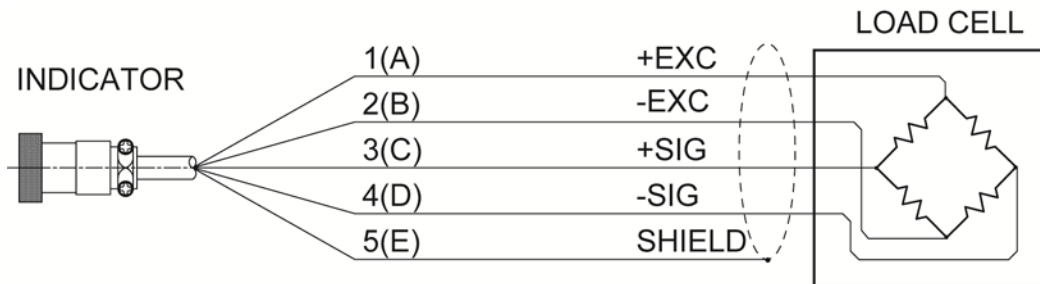

② I/O connector

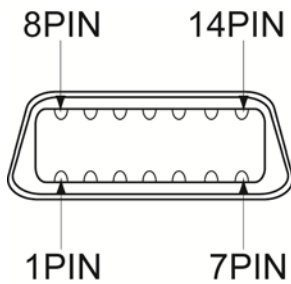

1	GND	DIGITAL GROUND	
2	IN1	HOLD IN	
3	IN2	ZERO IN	
4	IN3	SPARE	
5	IN4	SPARE	
6	GND	DIGITAL GROUND	
7	OUT1	COMPARATE RY1 (LOW)	OPEN COLLECTOR OUTPUT Active Low(Negative-logic output) External Voltage 50V Max
8	OUT2	COMPARATE RY2 (GOOD)	
9	OUT3	COMPARATE RY3 (HIGH)	
10	OUT4	SPARE	
11	VCC	Internal test voltage 3V	
12	N.C		
13	ANALOG +	DC 0 ~ +/-1V OUTPUT	
14	ANALOG GND	ANALOG GROUND	

6. Components and Functions

6-1. How to use the Hold Mode

The Hold mode is divided into Peak Hold and Sample Hold. Select and use it as needed.

The method of inputting Hold is via the Hold key on the front panel; it can also be done by external input. For the correct method, refer to the figures below:

1) Peak Hold: Hold the maximum value among measured values.

- Peak Hold Mode: Hold the maximum value of the forward direction (+), and indicate it.
- Absolute Peak Hold Mode: Hold the maximum value of the absolute value (+/-), and indicate it.

2) Sample Hold: Hold the value of the time of inputting the Hold signal, and indicate it.

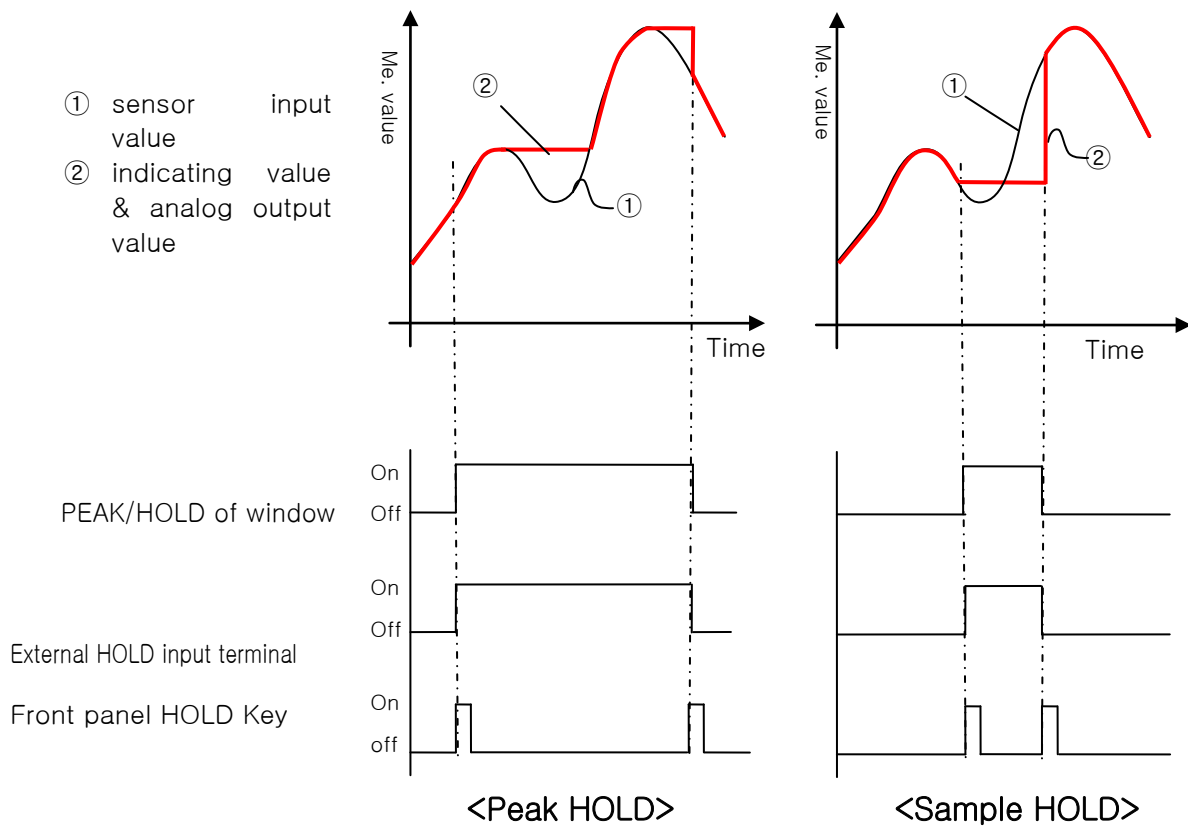

6-2. How to use the Compare Output Function

The Compare Output Function has 3 modes: Decision, High Limit, and Low Limit. Comparing each setting value, it is transmitted by an I/O Connector (Open Connector). Under the High Limit and Low Limit modes, hysteresis can be used.

1) Decision Mode

Measured value \leq Low Limit set value \Rightarrow RY1 ON (Low)

Measured value \geq High Limit set value \Rightarrow RY3 ON (High)

Low Limit set value $<$ Measured value $<$ High Limit set value \Rightarrow RY2 ON (Good)

2) High Limit Mode

Measured value \geq 1st set value \Rightarrow RY1 ON

Measured value \geq 2nd set value \Rightarrow RY2 ON

Measured value \geq 3rd set value \Rightarrow RY3 ON

Measured value $<$ 1st set value - Hysteresis value \Rightarrow RY1 OFF

Measured value $<$ 2nd set value - Hysteresis value \Rightarrow RY2 OFF

Measured value $<$ 3rd set value - Hysteresis value \Rightarrow RY3 OFF

3) Low Limit Mode

Measured value \leq 1st set value \Rightarrow RY1 ON

Measured value \leq 2nd set value \Rightarrow RY2 ON

Measured value \leq 3rd set value \Rightarrow RY3 ON

Measured value $>$ 1st set value + Hysteresis value \Rightarrow RY1 OFF

Measured value $>$ 2nd set value + Hysteresis value \Rightarrow RY2 OFF

Measured value $>$ 3rd set value + Hysteresis value \Rightarrow RY3 OFF

*** Note:** In the case of setting the Offset value, the Compare Output moves as follows:

1) Decision Mode

Measured value \leq (Offset - Low Limit set value) \Rightarrow RY1 ON (Low)

Measured value \geq (Offset + High Limit set value) \Rightarrow RY3 ON (High)

(Offset - Low Limit set value) $<$ Measured value $<$ (Offset + High Limit set value) \Rightarrow
RY2 ON (Good)

2) High Limit Mode

Measured value \geq (Offset + 1st set value) \Rightarrow RY1 ON

Measured value \geq (Offset + 2nd set value) \Rightarrow RY2 ON

Measured value \geq (Offset + 3rd set value) \Rightarrow RY3 ON

Measured value $<$ (Offset + 1st set value) - Hysteresis value \Rightarrow RY1 OFF

Measured value $<$ (Offset + 2nd set value) - Hysteresis value \Rightarrow RY2 OFF

Measured value $<$ (Offset + 3rd set value) - Hysteresis value \Rightarrow RY3 OFF

3) Low Limit Mode

Measured value \leq (Offset + 1st set value) \Rightarrow RY1 ON

Measured value \leq (Offset + 2nd set value) \Rightarrow RY2 ON

Measured value \leq (Offset + 3rd set value) \Rightarrow RY3 ON

Measured value $>$ (Offset + 1st set value) + Hysteresis value \Rightarrow RY1 OFF

Measured value $>$ (Offset + 2nd set value) + Hysteresis value \Rightarrow RY2 OFF

Measured value $>$ (Offset + 3rd set value) + Hysteresis value \Rightarrow RY3 OFF

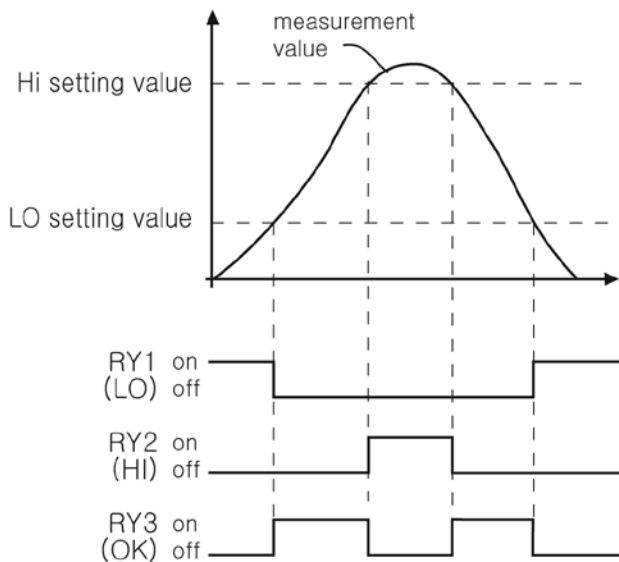

<Decision mode>

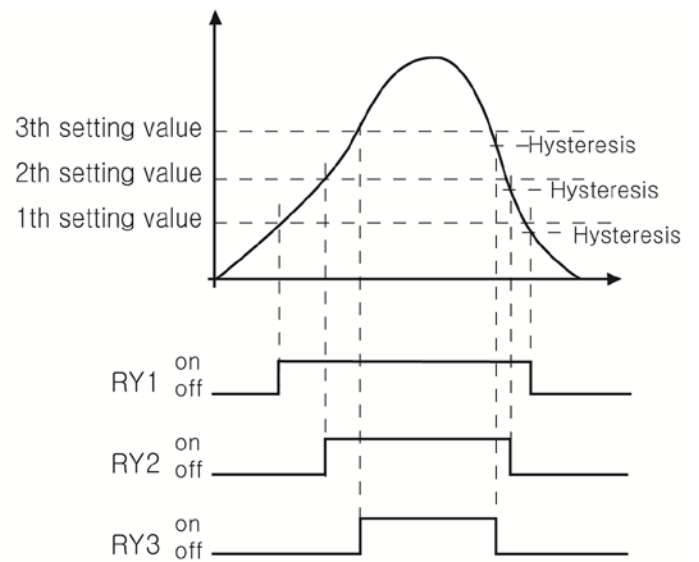

<High limit mode>

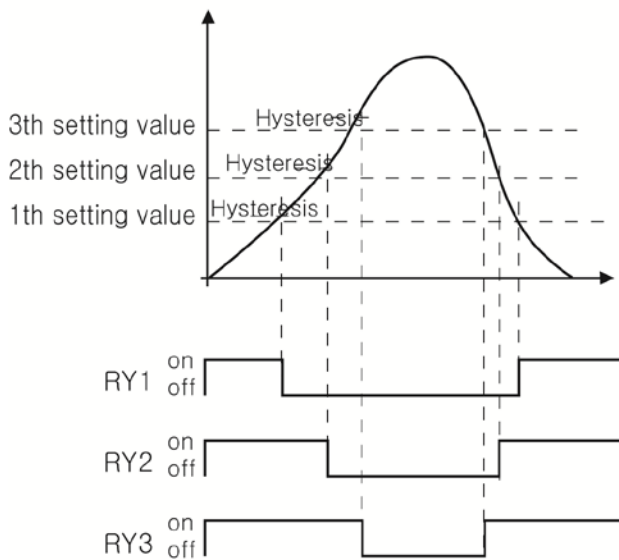

<Low limit mode>

7. Function Mode (Function Set-up)

1) How to Set up the Function

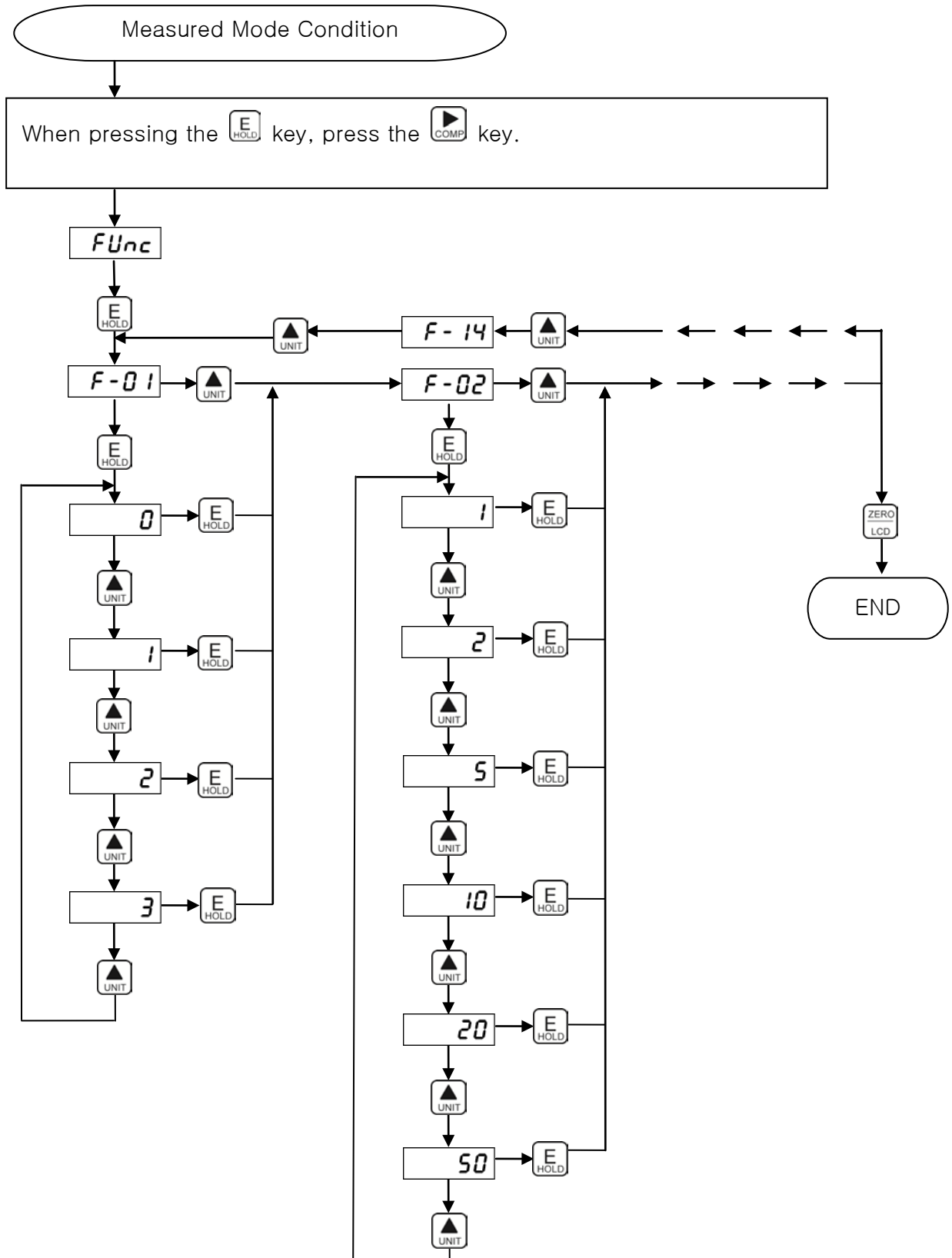

2) How to Set up the RELAY Output value

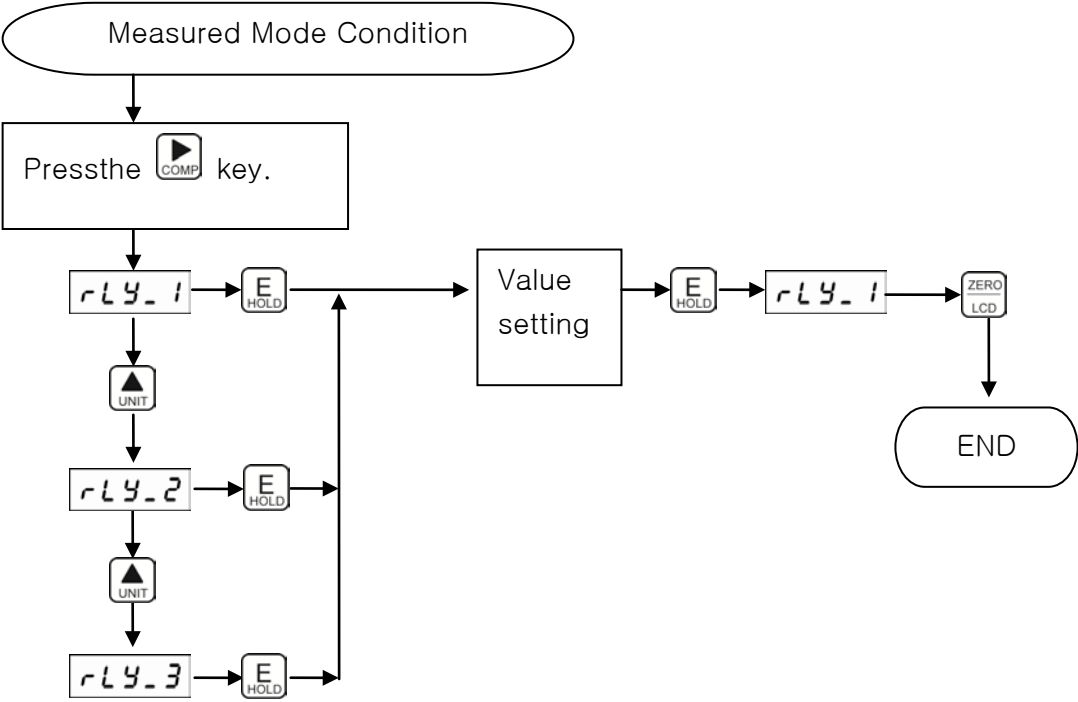

Function mode list

Name	Function	Setting	Standard set value at delivery time
F-02	Division	1, 2, 5, 10, 20, 50	1
F-03	Display Filter	4, 8, 16, 32, 64, 128	64
F-04	Hold Mode	Sample Hold (0), Peak Hold (1) Absolute Peak Hold (2)	2
F-05	Comparison Mode	Decision (0), High Limit (1), Low Limit (2)	0
F-06	Hysteresis	0 – 99	0
F-08	DAC Capacity	0 – 99999	10000
F-09	ID Number	0 – 32	1
F-10	Baud Rate	2400, 4800, 9600	9600
F-11	Auto Zero Tracking	0 – 99	0
F-12	Auto Zero Tracking Time	0.0 – 5.0 sec.	0.0
F-20	Comparison Absolute	No (0), Yes (1)	1
F-21	Auto Power Off	No (0), Yes (1)	1
F-22	Power On Zero	No (0), Yes (1)	1
F-23	Zero Offset	0 – 99999	0
F-24	Reverse Sign	No (0), Yes (1)	0

F-02. Division (Minimum Indicating Unit Set-up)

(Standard set value: 1)

Display Data	Setting
1	Indicate 1 unit (0, 1, 2, 3, 4 …….)
2	Indicate 2 units (0, 2, 4, 6, 8 …….)
5	Indicate 5 units (0, 5, 10, 15 …….)
10	Indicate 10 units (0, 10, 20, 30 …….)
20	Indicate 20 units (0, 20, 40, 60 …….)
50	Indicate 50 units (0, 50, 100, 150 …….)

F-03. Display Filter (Indicating Speed Set-up)

(Standard set value: 64)

Display Data	Setting
4	Average time: 1/32 of a second
8	Average time: 1/16 of a second
16	Average time: 1/8 of a second
32	Average time: 1/4 of a second
64	Average time: 1/2 of a second
128	Average time: 1 second

F-04. Hold Mode

(Standard set value: 2)

Display Data	Setting
0	Sample Hold Hold the value of signal input time
1	Peak Hold (+) Hold the max. value during signal input
2	Absolute Peak Hold (+/-) Hold the max. absolute value during signal input

F-05. Comparison Mode

(Standard set value: 0)

Display Data	Setting
0	Decision Mode RY1 (Low), RY2 (Good), RY3 (High) Output
1	High Limit Mode RY1, RY2, RY3 Output
2	Low Limit Mode RY1, RY2, RY3 Output

F-06. Hysteresis

(Standard set value: 00)

Display Data	Setting
00	00 Hysteresis is not used
99	01 – 99 Hysteresis value is used (Decision Mode is not applied)

F-08. DAC Capacity (Setting of Analog Output value)

(Standard set value: 10000)

Display Data	Setting			
0	Setting of Analog output value			
99999	<Example of set value and output>			
	Set value		Voltage output (0 to +/-1V)	
	ZERO	CAPACITY	Indicating value	Output
	0	+10000	-10000	-1V
			0	0V
			+10000	+1V

F-09. ID Number (Setting of Communication Equipment Number)

(Standard set value: 01)

Display Data	Setting	
00	00	Equip. number is not set (Stream Mode: data is constantly transmitted)
32	01 - 32	Equip. number is set (Command Mode: data is transmitted by order)

F-10. Baud Rate (Setting of Communication Speed)

(Standard set value: 9600)

Display Data	Setting
2400	2400 bps
4800	4800 bps
9600	9600 bps

F-11. Auto Zero Tracking (Setting of Auto Zero Point Tracking Range)

(Standard set value: 00)

Display Data	Setting	
00	00	Auto zero point is not used
99	01 - 99	Auto zero point tracking range is set

F-12. Auto Zero Tracking Time (Setting of Auto Zero Point Tracking Time)

(Standard set value: 0.0)

Display Data	Setting	
00	0.0	Auto zero point is not used
5.0	0.1 - 5.0	Auto zero point tracking range is set (0.1 - 5.0 seconds)

F-20. Comparison Absolute (Setting of Comparison Output Absolute Value)

(Standard set value: 1)

Display Data	Setting
0	Absolute value comparison is not used
1	Within the absolute value, comparison output is used

F-21. Auto Power Off (Setting of Auto Power Off)

(Standard set value: 1)

Display Data	Setting
0	Auto power off is not used
1	Without pressing any key for 10 minutes, the power turns off (except while charging).

F-22. Power on Zero (Setting of Auto Zero Point when Power is On)

(Standard set value: 1)

Display Data	Setting
0	When Power is on, Auto Zero Point is not used
1	When Power is on, Auto Zero Point is used

F-23. Zero Offset (Offset Setting)

(Standard set value: 0)

Display Data	Setting
0	0: Offset is not used 1 - 99999: Offset value is set
99999	It is used when measuring by adding an arbitrary value (self-weight, etc.) Ex.: In the case the measured value = 100, offset = 20 is set, indicating value = 120 Note: In the case of setting the Offset value, know the comparison output movement.

F-24. Reverse Sign (Setting of Reverse Sign)

(Standard set value: 0)

Display Data	Setting
0	Reverse sign is not used
1	Use of Reverse sign; Current indicating sign (tension(+)/pressure(-) are indicated.

7-2. Actual Load Calibration

When using the calibrating method by adding the actual load (load, displacement, pressure) to the sensor, a standard load is needed.

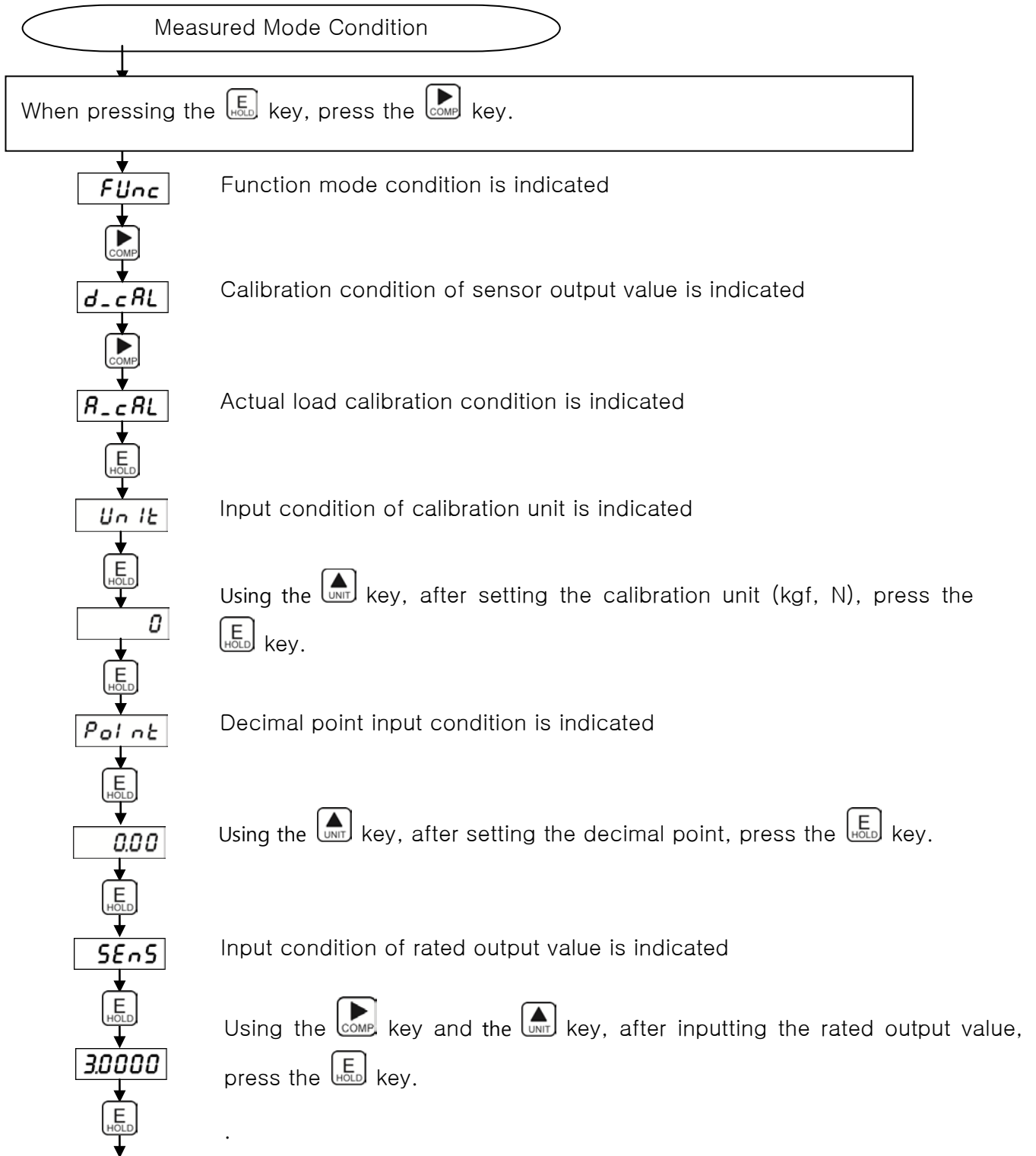

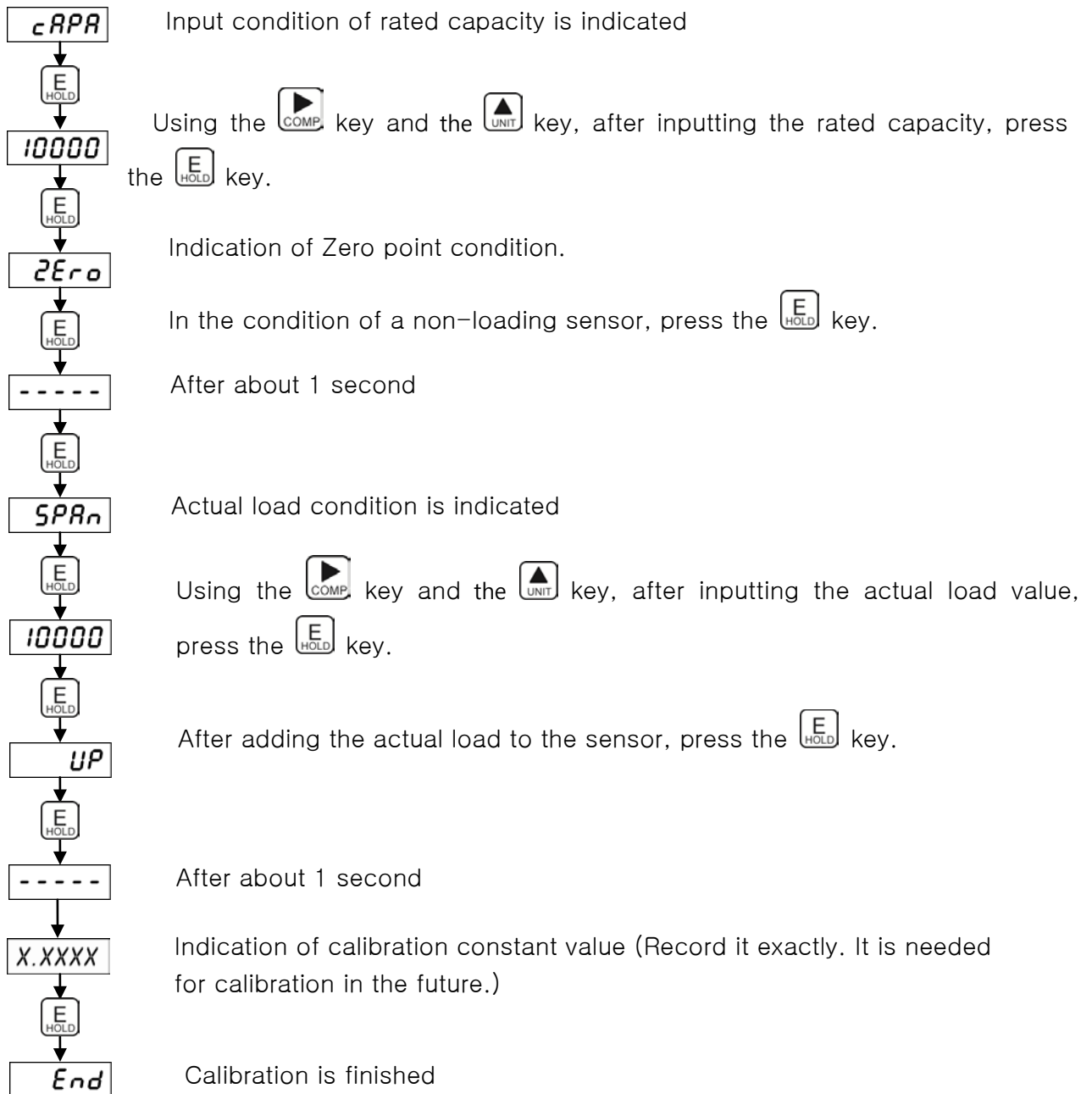

Cal. Date	R.O	calibration constant value

7-3 Lockdown Setting

With the lockdown setting, improper operation by an unnecessary key pressing can be prevented. After finishing the calibration, using the lockdown setting is recommended.

Initial condition begins when it is powered off.

Corresponding function when lockdown is set: Calibration-related function

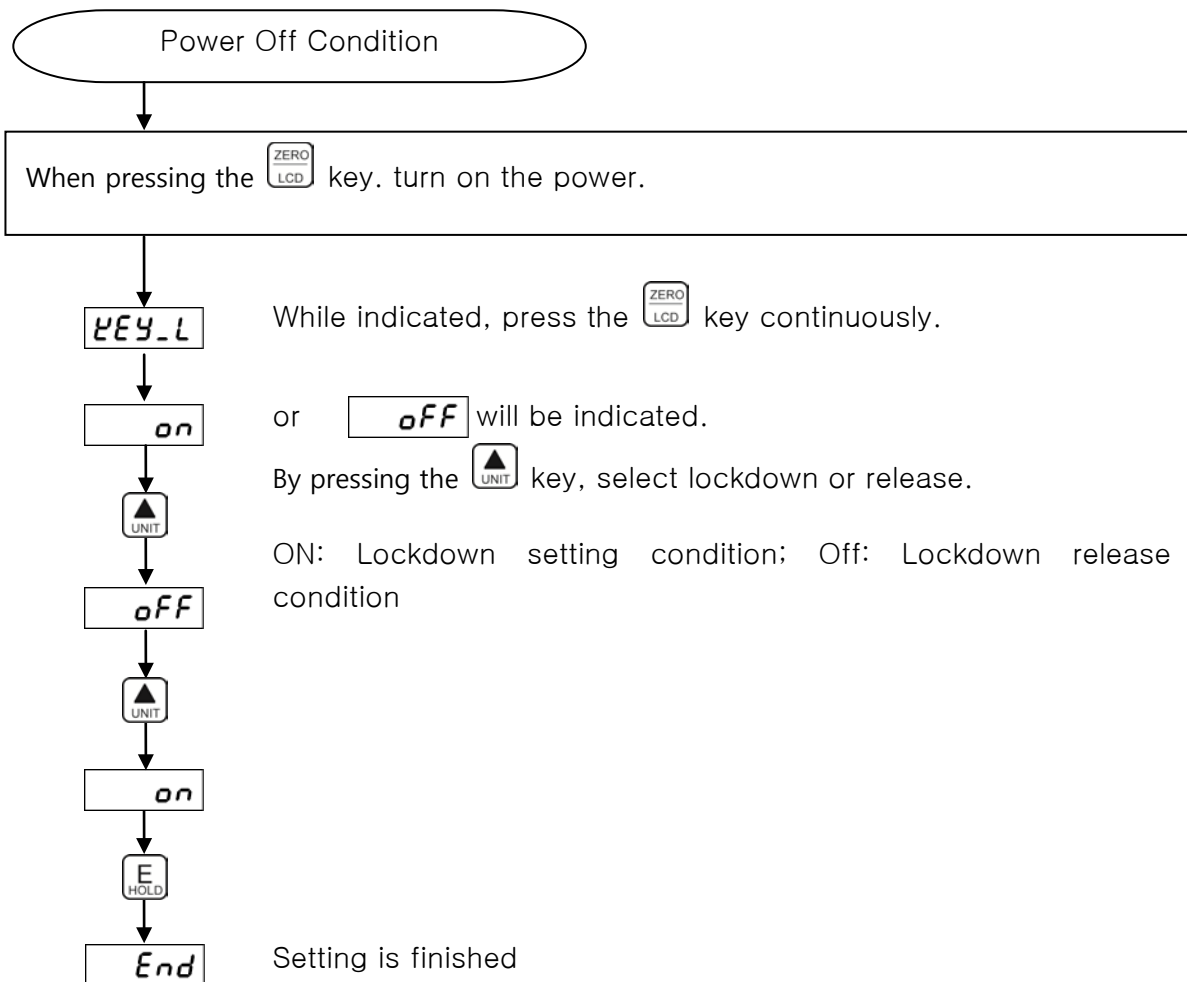

8. Communication (USB)

Before use, install a USB driver on the PC.
(<http://www.silabs.com>, search CP2102 drive)

1. Method: Half Duplex, Asynchronous Method
2. Baud Rate: Select among 2400, 4800, or 9600 bps
3. Parity: No Parity
4. Data Bit: 8-bit
5. Stop Bit: 1-bit

8-1. Stream Mode

When the equipment number (ID number of F-09) is 0, it operates under Stream Mode.

Data +1234.5Kgf Transmission

CODE	BYTE1	BYTE2	BYTE3	BYTE4	BYTE5	BYTE6	BYTE7	BYTE8	BYTE9
ASCII	S	T	,	N	T	,	+	0	1
HEX	53H	54H	2CH	4EH	54H	2CH	2BH	30H	31H

CODE	BYTE10	BYTE11	BYTE12	BYTE13	BYTE14	BYTE15	BYTE16	BYTE17
ASCII	2	3	4	.	5	K	C	LF
HEX	32H	33H	34H	2EH	35H	4BH	0DH	0AH

- 1) BYTE1, BYTE2
DATA Stable: ST
DATA Unstable: US
DATA OVERFLOW: OL
- 2) BYTE3 – BYTE6: Fixed letter (NT)
- 3) BYTE7 – BYTE14: DATA 8 BYTE (+/- included)
- 4) BYTE15: Measuring unit (K: Kgf; N: N; L: lbf; O: ozf)
- 5) BYTE16: CARRIAGE RETURN
- 6) BYTE17: LINE FEED

8-2. Command Mode

When the equipment number (ID number of F-09) is 1-32, it operates under the Command Mode.

1. Command Form (PC → INDICATOR)

CODE	BYTE1	BYTE2	BYTE3	BYTE4	BYTE5
ASCII	I	D	0	1	P
HEX	49H	44H	30H	31H	50H

- 1) BYTE1, BYTE2: Fixed letter (ID)
- 2) BYTE3, BYTE4: Equipment number (1-32)
- 3) BYTE5: Command (P, H, R, Z)

2. Command Table

Command		Explanation of Command
ASCII	HEX	
P	50H	Current value of order equipment is transmitted
H	48H	HOLD operation of commanding equipment
R	52H	HOLD release of commanding equipment
Z	5AH	ZERO operation of current value of commanding equipment

3. Transmission DATA Form (INDICATOR → PC)

CODE	BYTE1	BYTE2	BYTE3	BYTE4	BYTE5	BYTE6	BYTE7	BYTE8	BYTE9
ASCII	I	D	0	0	1	,	+	0	1
HEX	53H	54H	30H	30H	31H	2CH	2BH	30H	31H

CODE	BYTE10	BYTE11	BYTE12	BYTE13	BYTE14	BYTE15	BYTE16	BYTE17
ASCII	2	3	4	.	5	K	C	LF
HEX	32H	33H	34H	2EH	35H	4BH	0DH	0AH

- 1) BYTE1, BYTE2: Fixed letter (ID)
- 2) BYTE3 – BYTE5: Equipment number (1-32)
- 3) BYTE6: Fixed letter (,)
- 4) BYTE7 – BYTE14: DATA 8byte (+/- included)
- 5) BYTE15: Measuring unit (K: Kgf; N: N; L: lbf; O: ozf)
- 6) BYTE16: CARRIAGE RETURN
- 7) BYTE17: LINE FEED

8-3. Memo Data Transmission

It operates under the Command Mode.

1. Command Form (PC → INDICATOR)

CODE	BYTE1	BYTE2	BYTE3	BYTE4	BYTE5
ASCII	A	0	0	1	P
HEX	41H	30H	30H	31H	50H

- 1) BYTE1, BYTE2: Fixed letter (A)
- 2) BYTE3, BYTE4: Saving Data Address (1-500)
- 3) BYTE5: Command (P, D, U)

2. Command Table

Command		Explanation of Command
ASCII	HEX	
P	50H	Data transmission of designated address
D	44H	AD001 and up to designated address data transmission
U	55H	At designated address, up to AD500 data transmission

3. Transmission DATA Form (INDICATOR → PC)

CODE	BYTE1	BYTE2	BYTE3	BYTE4	BYTE5	BYTE6	BYTE7	BYTE8	BYTE9
ASCII	A	D	0	0	1	,	+	0	1
HEX	41H	54H	30H	30H	31H	2CH	2BH	30H	31H

CODE	BYTE10	BYTE11	BYTE12	BYTE13	BYTE14	BYTE15	BYTE16	BYTE17
ASCII	2	3	4	.	5	K	C	LF
HEX	32H	33H	34H	2EH	35H	4BH	0DH	0AH

- 1) BYTE1, BYTE2: Fixed letter (AD)
- 2) BYTE3 – BYTE5: Saving Data Address (1-500)
- 3) BYTE6: Fixed letter (,)
- 4) BYTE7 – BYTE14: DATA 8byte (+/- included)
- 5) BYTE15: Measuring unit (K: Kgf; N: N; L: lbf; O: ozf)
- 6) BYTE16: CARRIAGE RETURN
- 7) BYTE17: LINE FEED

9. Product Check

Trouble	Cause	Action	Comments
Display is shaking	<ul style="list-style-type: none"> • Load cell is broken • Load cell insulation resistance • Interference occurs 	<ul style="list-style-type: none"> • Load cell input, output • Check resistance • Check load cell insulation resistance 	<ul style="list-style-type: none"> • Insulation resistance (Cable & Case 1000 Mohm and more)
Weight increases at a fixed rate or does not return to zero	<ul style="list-style-type: none"> • Bad load cell 	<ul style="list-style-type: none"> • Check load cell insulation resistance 	
	<ul style="list-style-type: none"> • Imperfect access of load cell 	<ul style="list-style-type: none"> • Check wire connection between load cell and this instrument • Check cutting of load cell cable 	
“OVER” or “UNDER” is indicated	<ul style="list-style-type: none"> • Load cell is broken • Load cell connection is bad 	<ul style="list-style-type: none"> • Check load cell condition and cable connection condition 	