

Pedal Effort Load Cell

>Model CS285

Made of aluminum alloy material.
Used to measure the brake pedal force in the car development industry.
Protection Class IP65
Capacity: 1000N, 2000N, 2500N

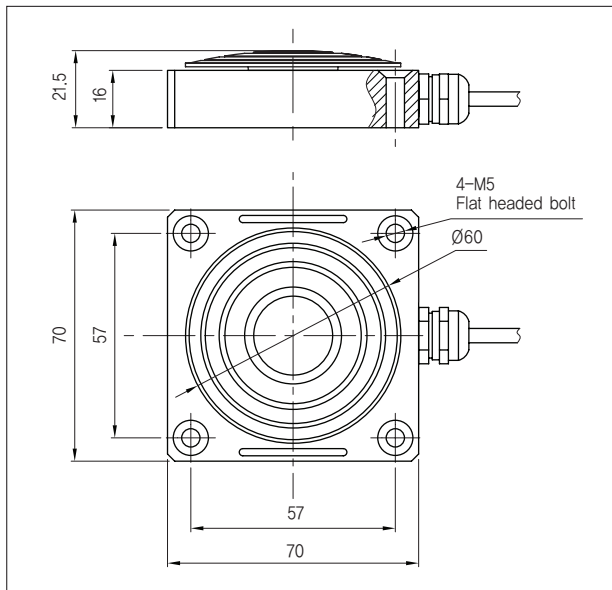

>SPECIFICATIONS

Specifications	Accuracy
Rated output(R.O)	1.5±10% mV/V
Zero balance	±2% F.S.
Nonlinearity	0.25% F.S.
Hysteresis	0.1% F.S.
Repeatability	0.1% F.S.
Creep [30min]	0.2% F.S.
Temperature effect, on rated output	0.05% F.S. / 10°C
Temperature effect, on zero	0.03% F.S. / 10°C
Terminal resistance input	700±30Ω
Terminal resistance output	700±10Ω
Insulation	2000MΩ
Excitation recommended	10V
Excitation maximum	15V
Temperature range, compensated	-10~60°C
Temperature range, operation	-20~80°C
Safe overload	120% F.S.
Ultimate overload	200% F.S.
Cable length	Ø5, 4core cable 3m

>Model CS187

Pedal effort load cell
Small and light weight

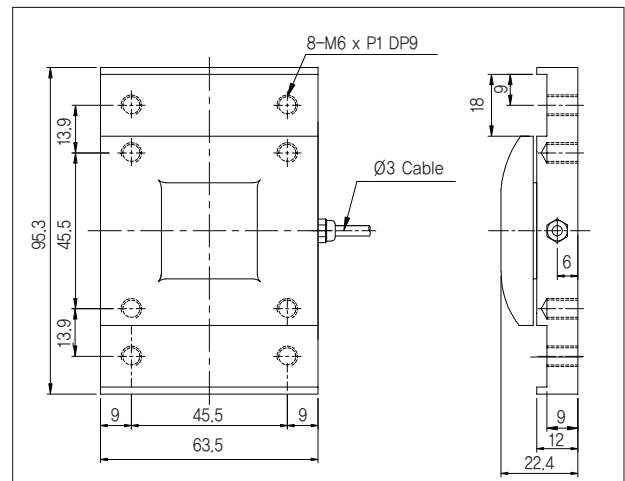
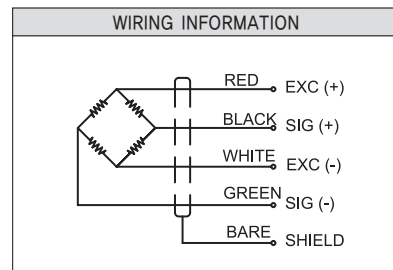

>SPECIFICATIONS

Specifications	Accuracy
Rated capacity(R.C)	120kgf(1200N)
Rated output(R.O)	1.2mV/V±1%
Nonlinearity	0.15% R.O.
Hysteresis	0.15% R.O.
Repeatability	0.15% R.O.
Zero balance	±1% R.O.
Temperature range, compensated	-10°C ~ 50°C
Temperature effect, on rated output	±0.02%LOAD/10°C
Temperature effect, on zero	±0.02%R.O./10°C
Terminal resistance input	700±10Ω
Terminal resistance output	700±5Ω
Insulation resistance bridge to ground	2000MΩ
Electrical connection	Ø3mm x 4C x 40cm
Excitation recommended	10V
Safe overload	150% R.C.

★Specifications are subject to change without notice.