

Low Profile Compression Load Cell

>Model CL63

Low Profile Compression Service Load Cell,
Hopper, Tank Weighing
CL : Protection Class IP67

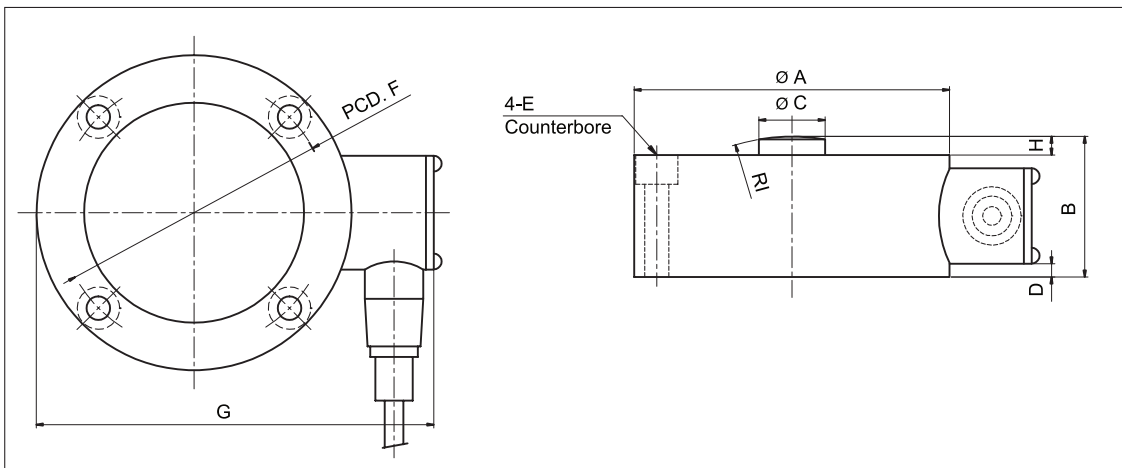

>SPECIFICATIONS

Specifications	Accuracy
Rated capacity(R.C)	500kgf, 1tf, 2tf, 5tf, 10tf, 15tf, 20tf, 30tf, 50tf, 100tf
Rated output(R.O)	2.0 mV/V±0.1%
Nonlinearity	0.05% of R.O.
Hysteresis	0.05% of R.O.
Repeatability	0.03% of R.O.
Zero balance	±2% R.O.
Temperature effect on rated output	0.05% of LOAD/10°C
Temperature effect on zero balance	0.03% of R.O./10°C
Temperature range, compensated	-10~60°C
Temperature range, safe	-20~80°C
Terminal resistance input	700±30Ω
Terminal resistance output	700±3Ω
Insulation resistance bridge	2000MΩ
Excitation recommended	10V
Safe overload	150% R.C.
Cable length	Ø7mm 4core, 3m

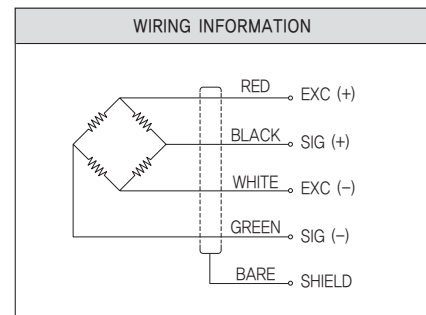

>DIMENSIONS TABLE

Model	ØA	B	ØC	D	E	PCD. F	G	H	RI
500kgf	88	28	16	1.5	M6	73	119	5	60
1tf	88	28	16	1.5	M6	73	119	5	60
2tf	104	44	22	1.5	M8	86	135	7	60
5tf	104	44	22	1.5	M8	86	135	7	60
10tf	119	53	25	1.5	M8	102	150	7	80
15tf	144	65	45	7	M10	118	175	7	100
20tf	144	65	45	7	M10	118	175	7	100
30tf	189	67	55	7	M12	158	220	10	140
50tf	189	67	55	7	M12	158	220	10	140
100tf	226	100	70	23.5	M16	190	257	10	160

*Specifications are subject to change without notice.